



BIN110



The BIN110 from Brema is a commercial ice bin built to withstand daily commercial usage in professional kitchens and bars. The insulated construction ensures safe ice storage to support operation efficiency and minimize product loss during service hours.

FEATURES

- The insulated ice bin body preserves an ideal temperature for ice preventing quick melting.
- Hygienic interior surfaces are suitable for direct contact with food products.
- The stainless steel exterior offers durability, corrosion resistance, and easy maintenance.
- This bin is compatible with modular ice machines from Brema.
- The model is ideal small volume operations.



PARTS AND
LABOR



SPECIFICATIONS

Storage capacity: 220 lb (100 kg)

Adjustable feet:
3.9" – 6.2" (10 to 16 cm)

Dimensions:
Length: 32" (81 cm)
Width: 22" (56 cm)
Height: 39.3" (100 cm)

Net weight: 152 lb (68 kg)

Shipping dimensions:
Length: 34.6" (88 cm)
Width: 24.4" (62 cm)
Height: 46.2" (117 cm)

Shipping weight: 143 lb (65 kg)

Compatible with

- G160AHC
- G280AHC
- TM140AHC
- TM250AHC





BIN110

FRONTAL VIEW

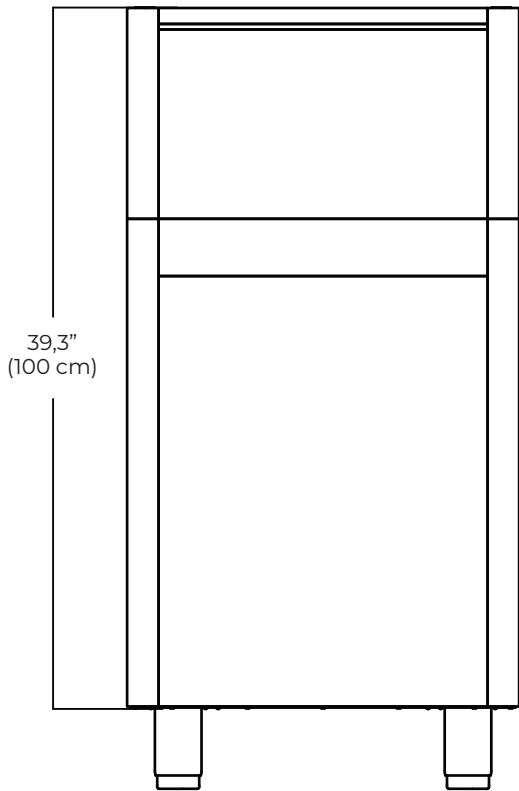

TOP VIEW

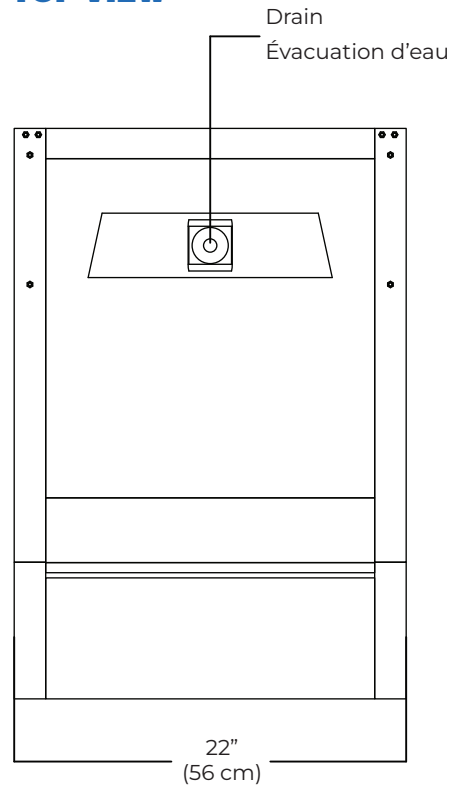

SIDE VIEW

