



BIN350



The BIN350 from Brema is a commercial ice bin built to withstand daily commercial usage in professional kitchens and bars. The insulated construction ensures safe ice storage to support operation efficiency and minimize product loss during service hours.

FEATURES

- The insulated ice bin body preserves an ideal temperature for ice preventing quick melting
- Hygienic interior surfaces are suitable for direct contact with food products
- The stainless steel exterior offers durability, corrosion resistance, and easy maintenance
- This bin is compatible with modular ice machines from Brema
- This model is ideal for high volume operations



PARTS AND
LABOR



SPECIFICATIONS

Storage capacity: 772 lb (350 kg)

Adjustable feet:
3.9" – 6.2" (10 to 16 cm)

Dimensions:
Length: 32" (81 cm)
Width: 49.2" (125 cm)
Height: 39.3" (100 cm)

Net weight: 225 lb (102 kg)

Shipping dimensions:
Length: 33.4" (85 cm)
Width: 51.1" (130 cm)
Height: 46.4" (118 cm)

Shipping weight: 266 lb (120 kg)

Compatible with

- G280AHC
- TM250AHC





BIN350

TOP VIEW

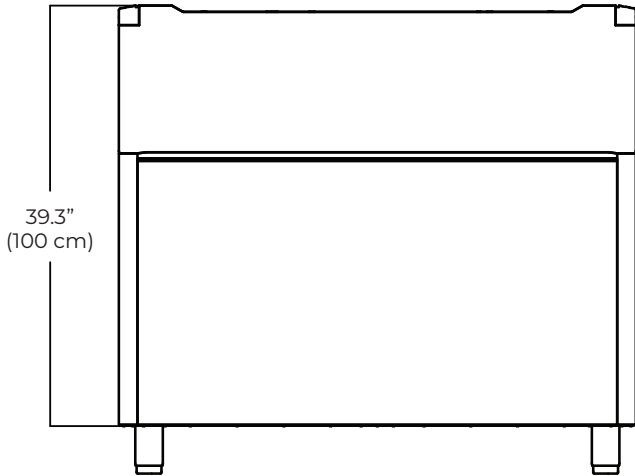

LEFT VIEW

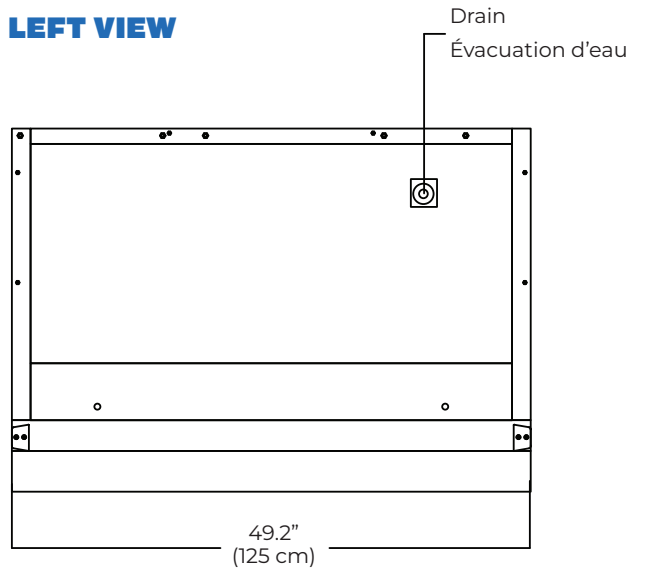

FRONTAL VIEW

