

eurodib

M20B



The M20B planetary mixer will help you with your culinary creations. It's robust construction and powerful motor will effortlessly mix, knead and emulsify the ingredients guaranteeing consistent results every time.

FEATURES

- Compact design ideal for medium-sized kitchens.
- Durable stainless steel construction guaranteeing long-term reliability and consistent performance.
- Intuitive controls for simple user-friendly operation.
- Exceptional value with quality assurance for professional results.
- This mixer is **NOT** suited for mixing bread or pizza dough.



PARTS AND
LABOR

CAPACITY CHART

Bowl size:	21 qt. (20 L)
Egg whites:	1.1 qt. (1 L)
Marshmallow:	2.2 lb (1 kg)
Cake batter:	15.5 lb (7 kg)
Cookie dough:	12 lb (5.5 kg)
Bread dough:	NOT SUITABLE
Pizza dough:	NOT SUITABLE

SPECIFICATIONS

Power:	110 V, 1100 W, 9 A, 5-15P
Capacity:	20 qt. (18 L)
Bowl depth:	12" (30 cm)
Bowl diameter:	14" (35 cm)
Mixing speed:	113/168/386 rpm
Max. kneading cap.:	13 lb/h (6 kg/h)
Dimensions:	
Length:	21.5" (54 cm)
Width:	17.5" (44 cm)
Height:	30.6" (77 cm)

Connection:  (110 V)

Net weight:	216 lb (98 kg)
Shipping dimensions:	
Length:	42" (106 cm)
Width:	32" (81 cm)
Height:	31" (78 cm)
Shipping weight:	295 lb (133 kg)

Included accessories

- Bowl
- Spiral hook
- Whip
- Beater
- Meat grinder attachment



FRONTAL VIEW

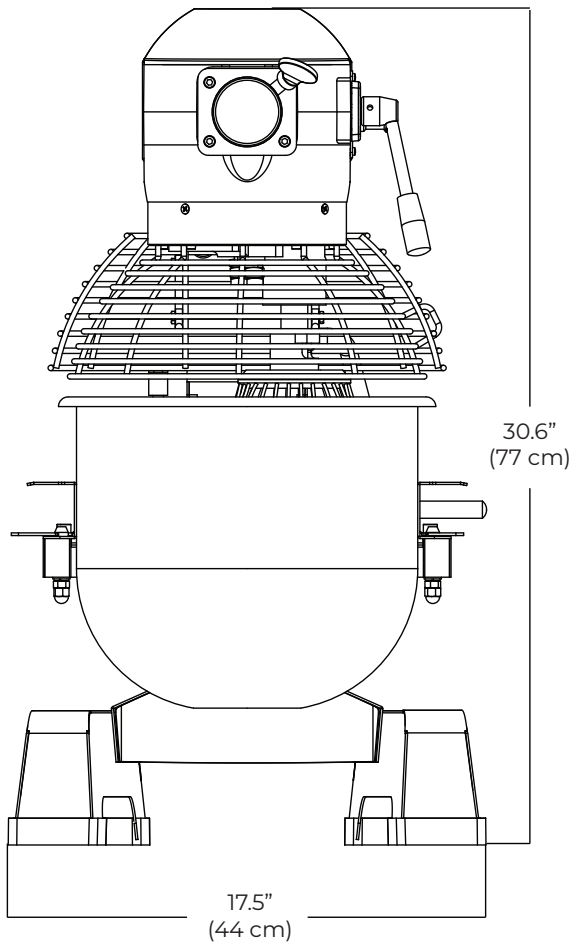

TOP VIEW

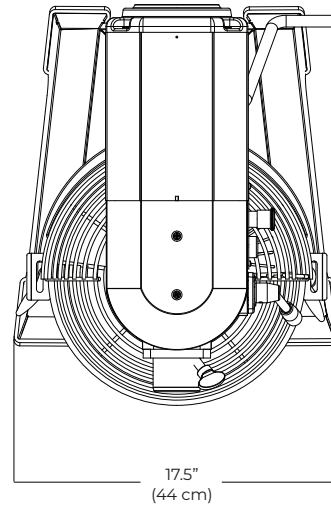

LEFT VIEW

