

# eurodib

## M30AETL220



Achieve superior mixing performance with Eurodib's M30AETL Planetary Mixer. Designed for professional kitchens, this mixer combines durability and precision to handle a wide range of batters and creams with ease. Featuring 3 speed settings, it ensures consistent results for bakeries, restaurants, and catering operations.

### FEATURES

- Robust design built for heavy-duty in professional kitchens.
- 30-quarts capacity with 3 speed settings to prepare multiple recipes.
- User-friendly controls ensure simple and efficient operation.
- Durable construction guarantees long-term reliability.
- Exceptional value with quality assurance for professional results.
- This mixer is **NOT** suited for mixing bread or pizza dough.



PARTS AND  
LABOR

### CAPACITY CHART

Bowl size:	32 qt. (30 L)
Egg whites:	1.5 qt. (1.4 L)
Marshmallow:	2.2 lb (1 kg)
Cake batter:	22 lb (10 kg)
Cookie dough:	17.5 lb (8 kg)
Bread dough:	<b>NOT SUITABLE</b>
Pizza dough:	<b>NOT SUITABLE</b>

### SPECIFICATIONS

Power:	220 V, 1500 W, 8 A, 6-20P
Capacity:	30 qt. (28 L)
Bowl depth:	15.5" (39 cm)
Bowl diameter:	15" (38 cm)
Mixing speed:	65/102/296 rpm
Max. kneading cap:	22 lb/h (9 kg/h)
Dimensions:	
Length:	26.4" (67 cm)
Width:	22.6" (57 cm)
Height:	41.3" (105 cm)

Connection:   
(220 V)

Net weight: 425 lb (192 kg)

Shipping dimensions:  
Length: 48" (121 cm)  
Width: 40" (101 cm)  
Height: 54" (137 cm)

Shipping weight: 510 lb (231 kg)

### Included accessories

- Bowl
- Spiral hook
- Whip
- Beater



**FRONTAL VIEW**

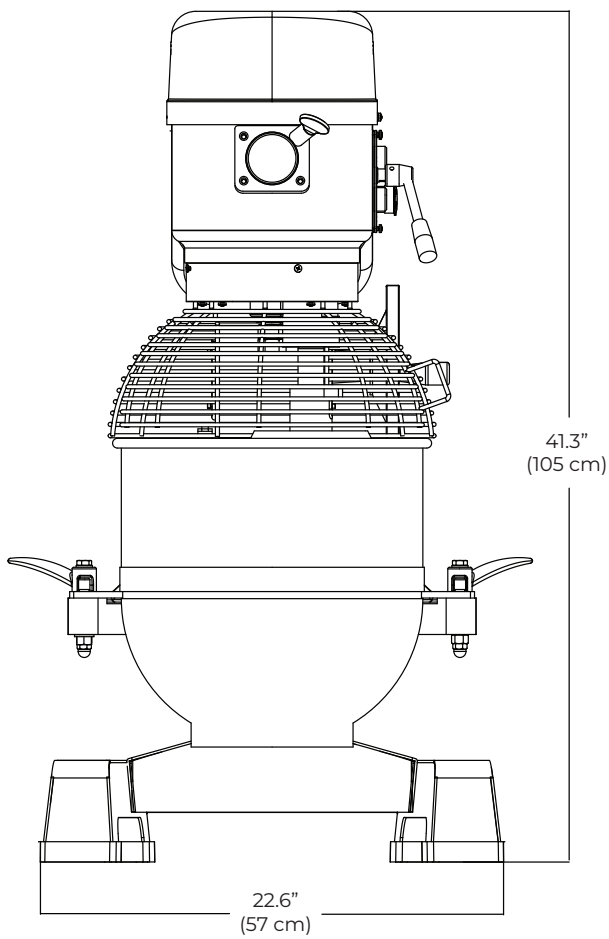

**TOP VIEW**

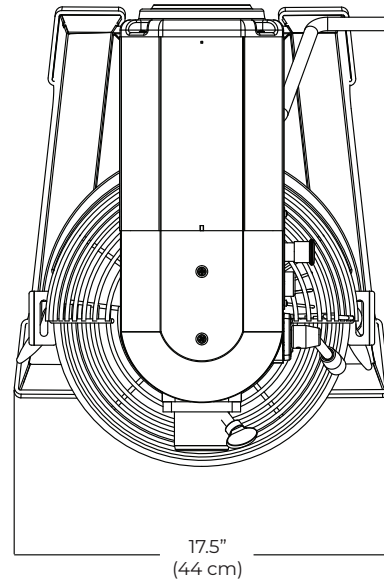

**LEFT VIEW**

