

eurodib

SFE01860D120



The Eurodib double basket fryer delivers uniform cooking results across a wide range of fried foods, making it an essential tool for professional kitchens. Its countertop design maximizes kitchen flexibility by allowing convenient placement that supports efficient workflow and fast service.

FEATURES

- Double basket design allows different ingredients to be fried simultaneously.
- Protective lid controls oil spills around the machine and prevents foreign contaminants in the fryer when it is not in use.
- Wide temperature range with indicator light for accurate heat monitoring.
- Removable oil tank simplifies oil replacement and routine maintenance.



PARTS AND
LABOR

SPECIFICATIONS

Power: 120 V – 1800 W – 15 A

Double basket

Capacity: 2.1 gal. (8 L)

Temperature range:
105 – 370 °F (40 – 187 °C)

Dimensions:
Length: 18" (46 cm)
Width: 11.1" (28 cm)
Height: 15.9" (40 cm)



Connection:

(120 V)

Net weight: 17 lb (7.7 kg)

Shipping dimensions:
Length: 22" (55 cm)
Width: 14" (35 cm)
Height: 21" (53 cm)

Shipping weight: 21 lb (9 kg)



TOP VIEW

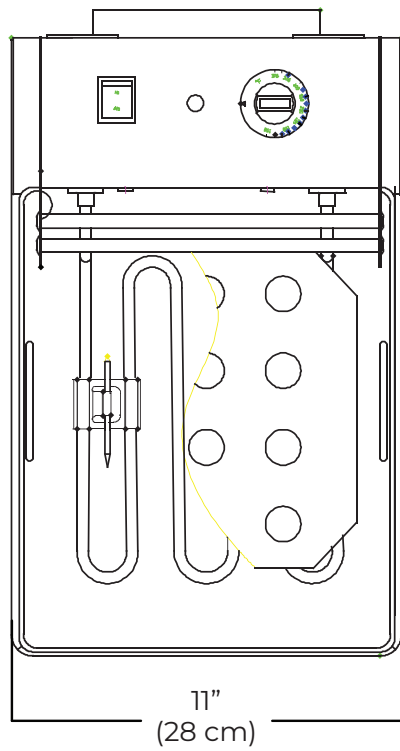

FRONTAL VIEW

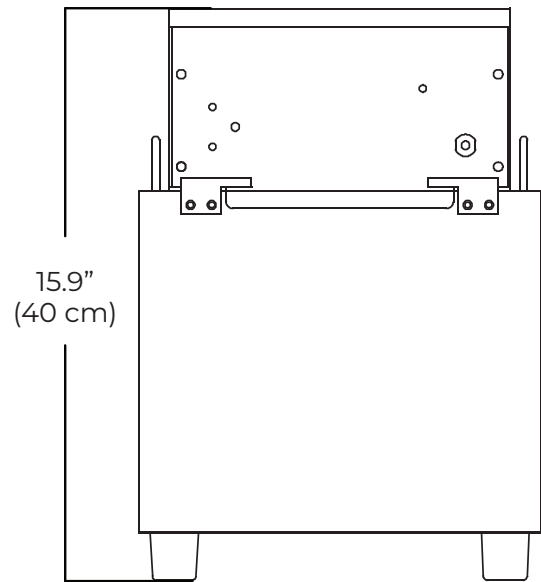

LEFT VIEW

