



INSTRUCTIONS FOR USE

BLAST-CHILLER

“NEW RUNNER” Series
FULL TOUCH Control Panel

BCT/05 US
BCT/10 US
BCT/15 US

Manual BCT US - Rev. 03-2026



www.gemm-srl.com

Explaining the pictograms

The installation and use instructions are valid for all models unless otherwise specified by the following pictograms:



Danger! Immediate danger situation or dangerous situation that could cause injury or death.



Read the instruction manual



Reference to another chapter



Earthing symbol



In-depth chapter or text



Equipotential symbol



Hot surfaces, danger of burns

Dear Installer/Customer

This booklet contains all the information necessary for a safe and correct installation and use of the equipment: We therefore recommend that you read it carefully before performing any operation and keep it carefully for future reference.

If there is need for further information or if some part of the booklet has not been understood, we remain available to answer all your questions.

Good luck with your job!

CONTENTS



INSTALLATION

Safety warnings.....	page 4
Technical data.....	page 10
Transport, unpacking and checking.....	page 14
Installation	page 16
Final checks	page 20



USE

Safety warnings.....	page 4
Preliminary knowledge	page 22
Use	page 26
Ordinary maintenance	page 42
After-sales service	page 46
Warranty and service	page 46

1 Safety warnings



Failure to comply with the following standards may cause damage and even fatal injuries, void the warranty and release the Manufacturer from all liability. Before installation, use and maintenance of the equipment, read this booklet carefully and keep it carefully for any further future consultation by the various operators. If you have not understood all the contents of this booklet, contact the Manufacturer. In case of loss or deterioration of the documentation, ask the Manufacturer for a replacement.

Who should read this manual

This manual is intended for both the operator and the technicians authorized to install and maintain the equipment. Operators must not carry out operations reserved for maintenance workers or specialized technicians. The manufacturer is not liable for any damages resulting from the failure to comply with this prohibition.



Specialized forklift operator: specialized operator, in charge of handling the equipment and equipped with a license for the use of forklifts.



Specialized electrician: specialized electrician who has attended the manufacturer's qualification courses that allow him any intervention on the equipment. The specialized electrician must be able to install the equipment and run it under normal conditions, is qualified for all electrical and mechanical adjustment interventions, maintenance and repair. He can operate in the presence of voltage inside electrical cabinets and junction boxes.



Operator charged with the use of the equipment: specialized personnel capable of operating the equipment in normal conditions using the relevant controls. He must also be able to perform simple routine maintenance operations (cleaning, loading the product), starting or restoring the equipment following a possible forced stop.

Using and storing the manual

- This manual aims to provide all the necessary information so that, in addition to using the equipment correctly, it is possible to manage it in the most autonomous and safe way possible.
- The manual is divided into chapters and paragraphs: therefore the index page provides an easy way to find any aspect of interest.
- The material contained in this document is provided for information's sake only and is subject to change without notice. Despite the utmost attention paid to the drafting of the document, the manufacturer is not responsible for damage resulting from errors or omissions and from the use of the information contained herein or from incorrect translations.
- Keep this manual, and all the attached documentation, in good condition, legible and complete with all its parts; keep it near the equipment, in a place accessible and known to all operators. If some parts are not understood, contact the Manufacturer.
- In case of transfer of the equipment, let the new user have this booklet.
- Keep clear of obstruction all ventilation openings in the appliance enclosure or in the structure for building-in.



Warnings for the forklift driver



All transport operations must be carried out only by qualified personnel authorized by the Manufacturer, according to the standards in force in the country of use, complying with the rules relating to systems and safety at work.



The driver must operate in perfect psychophysical conditions, must verify that the individual accident prevention devices are intact and fully functional and that there are no adverse conditions that can make handling difficult. The staff involved in these operations must NOT wear rings, watches, jewellery, unfastened or loose clothing, such as ties, torn clothing, scarves, unbuttoned jackets or shirts with open zips etc ... In general, staff must use accident prevention garments.



Handling other than that indicated in this booklet can cause injury or fatal accidents to the driver and damage to the equipment and structures of the installation site.



For the entire duration of the transport, the equipment must be kept upright on its pallet, wrapped in cardboard: this packaging must be secured to the means of transport with suitable tools (e.g. ropes) to prevent it from overturning or moving during handling. Never turn the equipment upside down or place it horizontally.



During the transport phase, the ambient temperature must never drop below 4°C/ 39,2°F.



All handling and lifting operations must be carried out with the utmost caution, checking that all personnel are strictly at a safe distance, and that no one stands under suspended, stationary or moving loads.



Before starting the operation, check the entire area of movement of the equipment, in order to detect the possible presence of dangerous points.



Always make sure that the forklift has a capacity greater than the weight of the equipment to be lifted: the operator of the forklift will be responsible for lifting the load. **The use of unsuitable equipment can lead to accidents to personnel carrying out the operation and/or damage to the equipment.**

The manufacturer accepts no responsibility for the improper and non-compliant use of lifting, transporting and handling devices.

- Depending on the type, size and weight, suitable packaging has been used to ensure integrity and preservation during transport up to the delivery to the buyer, for this reason do not remove it before or during transport.
- The equipment contains an airtight refrigeration circuit that contains flammable gas. For this reason, during transport, take care not to damage any component of the cooling circuit itself. In the event of damage, avoid naked flames or ignition sources, disconnect the appliance from the power supply, ventilate the room for a few minutes and notify technical service.



Warnings for the installer



Before installing the equipment, read this manual carefully and scrupulously follow the instructions provided.



All installation and extraordinary maintenance operations must be carried out only by qualified personnel authorized by the Manufacturer, in compliance with the standards in force in the country of use and to the rules relating to systems and safety at work.



The installer must operate in perfect psychophysical conditions, must verify that the individual accident prevention devices are intact and fully functional and that there are no adverse conditions that can make handling difficult.



Installation or maintenance other than that indicated in this booklet can cause injury or fatal accidents to the installer and user and damage to the equipment and structures of the installation site.

- During the installation of the equipment, the transit or stay of unauthorized persons near the work area is prohibited.
- Before installing the equipment, check the compliance of the systems with the regulations in force in the country of use and with what is indicated on the technical data plate.
- The equipment must be disconnected from the power supply before performing any installation or maintenance work.
- The deactivation of the protective devices must be carried out only by authorized personnel, who will ensure the safety of people and avoid any damage to the machine. After performing the necessary maintenance, the protective devices must be reactivated correctly.
- During maintenance or repair operations, unauthorized persons must keep far from the equipment.
- At the end of the maintenance or repair operations, it is possible to restart the equipment only after the specialized technician has ascertained that:
 - the works have been carried out completely;
 - the safety systems are active;
 - the equipment works perfectly;
 - nobody is operating the equipment.
- The replacement of the power supply cable must be carried out only by a qualified and authorized technician. The cable can only be replaced with one of similar characteristics: the type of cable to be used and its section is always indicated on the technical data plate. The grounding cable must always be yellow-green.
- With the appliance installed, the electric cable and the power outlet must be easily accessible.
- Interventions, tampering or modifications not expressly authorized that do not comply with the contents of this manual will void the warranty.
- The data plate provides important technical information: it is indispensable in case of a request for maintenance or repair of the equipment: we therefore advise you not to remove it, damage it or modify it.
- As potentially dangerous, the packaging material must be kept out of the reach of children or animals and properly disposed of according to local regulations.



Warnings for the user



Before the use and routine maintenance of the equipment, read this booklet carefully and keep it with care for any further future consultation by the various operators.



Any unauthorized tampering or replacement of one or more parts or components of the equipment, the use of accessories and consumables other than the originals, can be an accident risk and release the manufacturer from any civil or criminal liability. In case of doubts about the operation or the state of the equipment, do not use it and contact the manufacturer.



DANGER OF FROSTBITE: During its work phases, the equipment can manage very low temperatures, avoid direct contact with the internal parts of the machine immediately after opening the door.

Intended use

- This appliance is capable of rapidly lowering the core temperature of food.
- Any other use is improper and potentially dangerous.
- Do not store various objects, live animals, exposed liquids, corrosive or explosive substances such as spray cans with flammable substances in this appliance. This appliance is not suitable for storing and cooling medicines, plasma, laboratory preparations, substances and similar products indicated in the directive on medical devices. The Manufacturer is not liable for any damage caused by use other than that intended or by incorrect settings.
- The blast chiller must not be used:
 - for uses other than those stated in this chapter;
 - with faulty safety systems;
 - after an incorrect installation;
 - by untrained personnel;
 - with maintenance work not performed or performed incorrectly;
 - with the use of non-original spare parts;
 - with damaged power supply cable and/or plug;
 - with blocked ventilation ducts;
 - with the product to be processed placed close to the ventilation grilles, any ventilation ducts, or on the bottom of the cell.
- Do not store explosive substances, such as spray cans with flammable propellant in this appliance.

Maintenance and cleaning

- Any use, cleaning and maintenance other than those indicated in this booklet are considered improper and can cause damage, injury or fatal accidents, void the warranty and release the Manufacturer from all liability. Cleaning and maintenance performed by the user must not be carried out by children without supervision.
- In the event of a move, keep the appliance upright.
- To speed up the cleaning process, do not use mechanical devices or means other than those recommended by the manufacturer.
- The ordinary and extraordinary maintenance operations that require the opening of the electrical panel or even partial dismantling of the blast chiller must be carried out only by qualified personnel authorized by the Manufacturer.

Operating anomalies

- If the equipment does not work or you notice functional or structural anomalies, disconnect it from the electrical and water supply and contact a Service Centre authorized by the Manufacturer without attempting to repair it yourself. For any repairs, request the use of original spare parts. Failure to comply with this prescription will void the Warranty.
- To make sure that the appliance is in perfect conditions of use and safety, we recommend that you have it serviced and checked at least once a year by an authorized service centre.

Use

- The start-up and use of the equipment must be entrusted only to trained personnel. The behaviour of the operating personnel must in any case scrupulously comply with the accident prevention regulations in force in the country where the appliance is used.
- The user must know the position and functions of all the control devices and characteristics of the blast chiller.
- At the time of installation, all operating personnel must be properly trained on the risks of accidents, safety devices, general accident prevention regulations provided for by international directives and by the law in force in the country where the appliance is used.
- The appliance can be used by children under 8 years of age and by people with reduced physical, sensory or mental abilities, or without experience or necessary knowledge, provided that they are under surveillance or after they have received instructions relating to the safe use of the appliance and to the understanding of the inherent dangers. Children must not play with the appliance.
- It is advisable to monitor the equipment throughout its operation.
- In order to obtain the best performance from the equipment, the following indications must be complied with:
 - avoid keeping the door open for a long time; if it has been opened, wait a few moments before reopening it;
 - pack or protect food, especially if it contains flavourings or spices;
 - do not obstruct the front and/or rear ventilation ducts of the equipment; do not place the product to be processed close to the ventilation grilles, the ventilation ducts, or directly on the bottom of the cell;
 - arrange the food evenly, starting from the bottom upwards; vice versa, remove the food starting from the top down. The maximum load (evenly distributed) per tray or grille is equal to 40 kg;
 - use only accessories recommended by the manufacturer.
- The data plate provides important technical information: it is indispensable in case of a request for maintenance or repair of the equipment: we therefore advise you not to remove it, damage it or modify it.
- The refrigeration equipment has been built and designed with the appropriate precautions in order to guarantee the health and safety of the user and does not have dangerous edges, sharp surfaces or elements protruding from the overall dimensions. Its stability is guaranteed even with the door open, however it is forbidden to hang on it.
- In the event of a fire, do not use water, take a CO₂ (carbon dioxide) extinguisher and cool the area of the engine compartment down as quickly as possible.

INSTALLATION

Explaining the pictograms	2
Safety warnings	4
Who should read this manual.....	4
Using and storing the manual.....	4
Warnings for the forklift driver	5
Warnings for the installer	6
Warnings for the user	7
Intended use.....	7
Maintenance and cleaning.....	7
Operating anomalies	8
Use	8
Technical data	10
Installation diagram.....	11
BCT/05 US.....	11
BCT/10 US.....	12
BCT/15 US.....	13
Transport, unpacking and checking	14
Transport	14
Unpacking	14
Checking the appliance.....	15
Handling after unpacking.....	15
Installation.....	16
Choosing the position	16
Electrical connection	17
Connection to the waste water network.....	19
Final checks.....	20
Final checks	20



2 Technical data

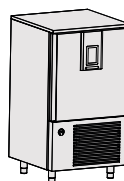
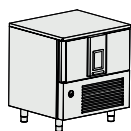

Model		BCT/05 US	BCT/10 US	BCT/15 US
External dimensions	cm	860x960x823	86x88x153	86x89x190
	inch	33.9x37.8x32.4"	33.8x34.7x61.4"	33.9x34.6x74.8"
Weight	kg	138	180	240
	lbs	304	397	530
Tray capacity	No.	5 18"x26" (cm 66x46) or GN 1/1	10 18"x26" (cm 66x46) or GN 1/1	15 18"x26" (cm 66x46) or GN 1/1
Internal cell temperature	°C / °F	+95/-40 °C / +203/-40 °F		
Load capacity	kg	+3°C ÷ +65 = 20 Kg +65°C ÷ -18°C = 12 Kg	+3°C ÷ +65 = 37 Kg +65°C ÷ -18°C = 24 Kg	+3°C ÷ +65 = 68 Kg +65°C ÷ -18°C = 49 Kg
	lbs	+37°F ÷ +149°F = 44 lb +149°F ÷ +0°C°F = 26 lb	+37°F ÷ +149°F = 81.5 lb +149°F ÷ +0°C°F = 53 lb	+37°F ÷ +149°F = 150 lb +149°F ÷ +0°C°F = 108 lb
Gas		R290		
Compressor power	Hp	1	1.25	2x 1.25
Max absorbed power	W	1045	1871	3050
Max absorbed current	A	11.4	14	9.6
Supply voltage	Volt	1x115V ~ 60 Hz plug NEMA 5-20P / 5-15P cable length 2.5 m [98.4"]	1x230 ~ 60 Hz plug NEMA 6-20P / 6-15P cable length 2.5 m [98.4"]	3x230 ~ 60 Hz
Refrigerated power (-10°F/+130°F)	Btu/h	3445	6412	10538

Installation location	Bakeries, pastry shops, ice cream parlours and kitchens in general
Air relative humidity	< 80% without condensation
Climate class	5 (+40°C / +104°F 40% HR)

Installation diagram

BCT/05 US

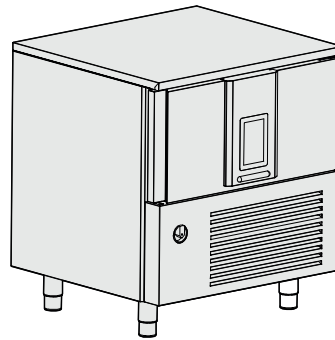
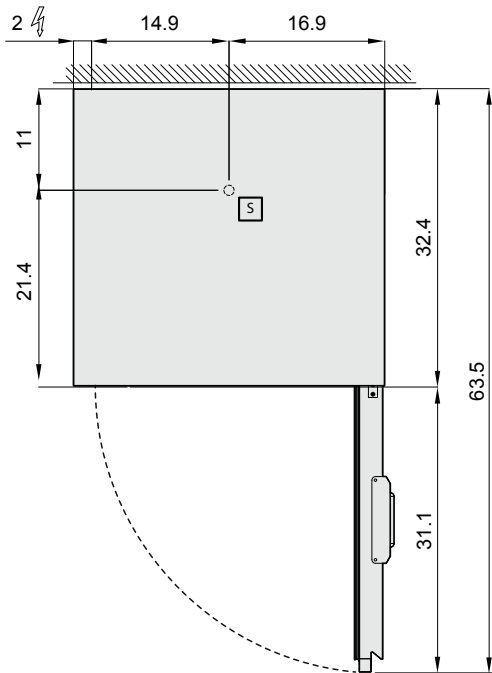
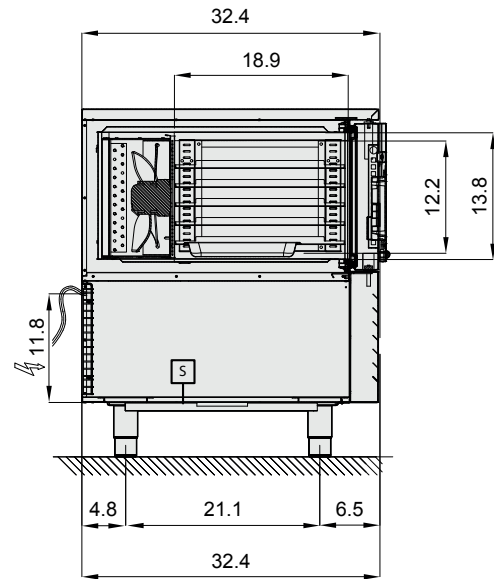
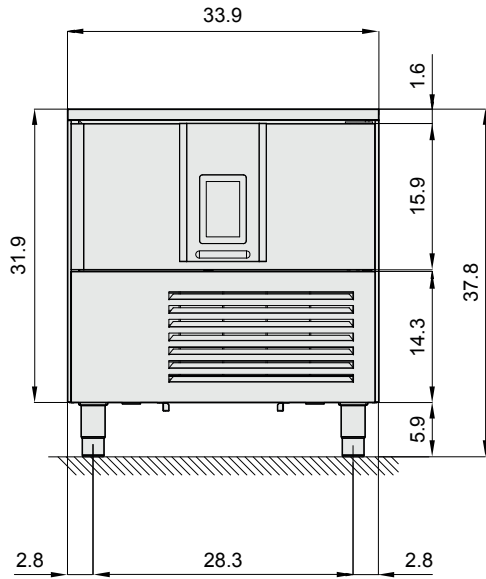

inch

S DRAINING WATER = 17 HOLES, INT. 0.69", L=11"



BCT/10 US

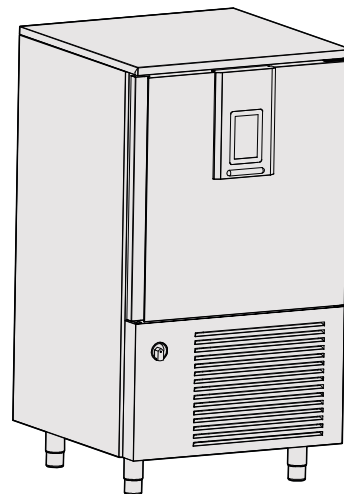
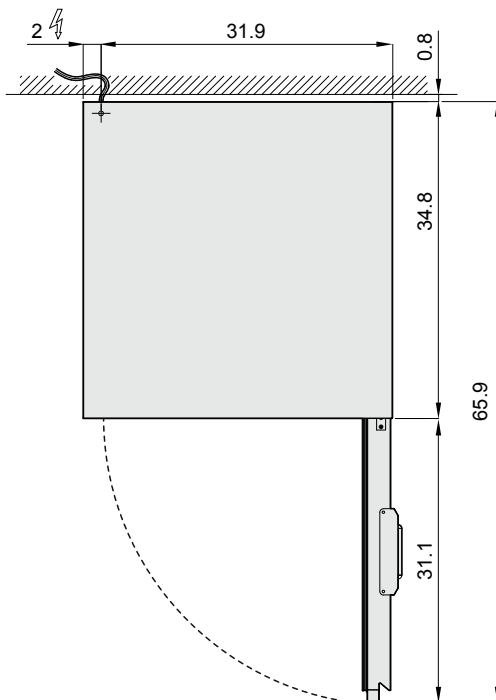
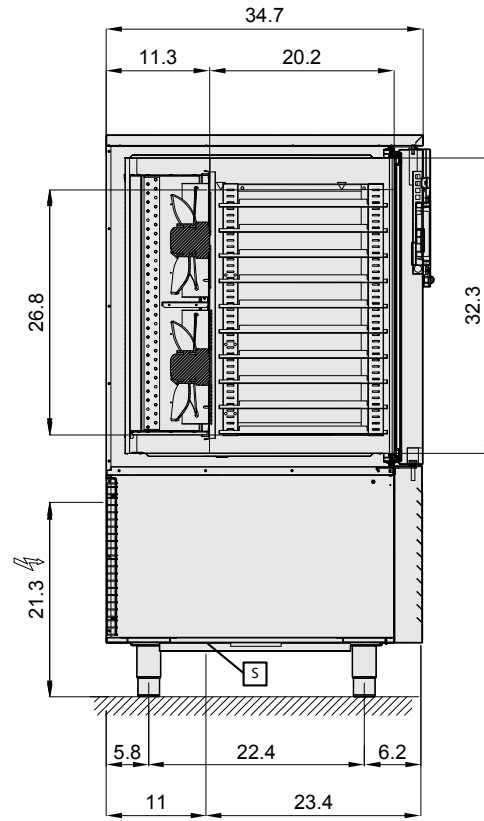
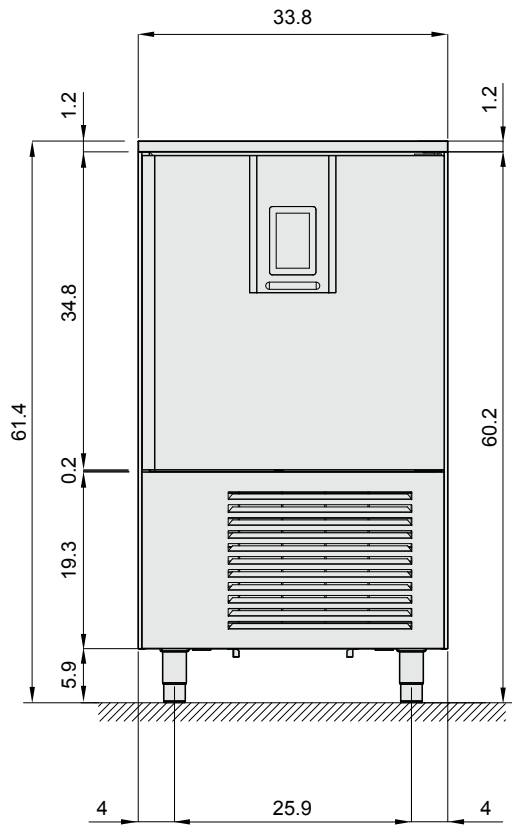

inch

S DRAINING WATER = 17 HOLES, INT. 0.69", L=11"

BCT/15 US

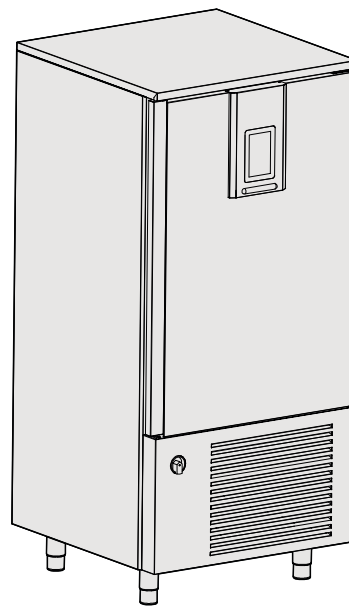
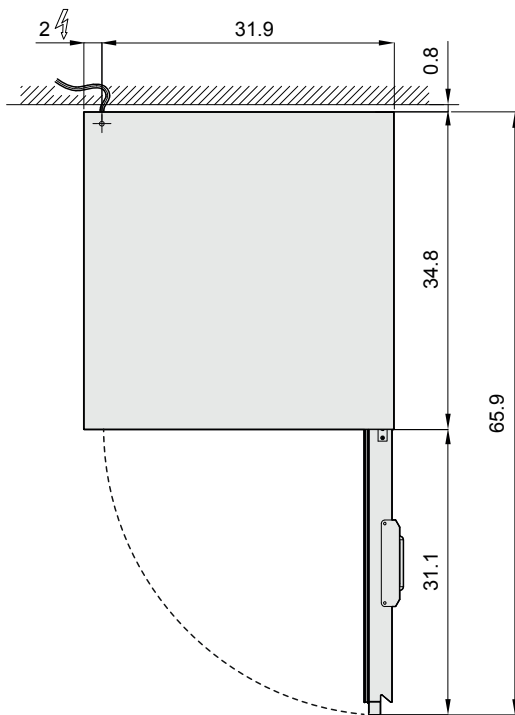
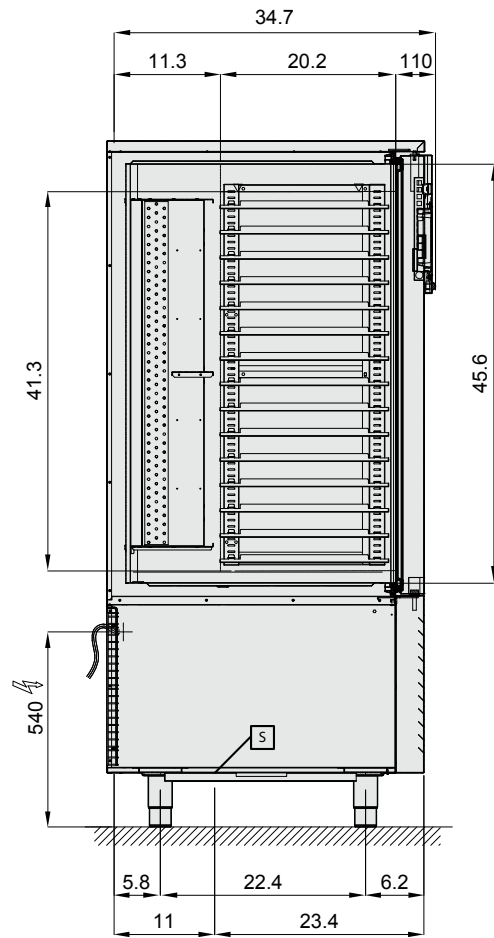
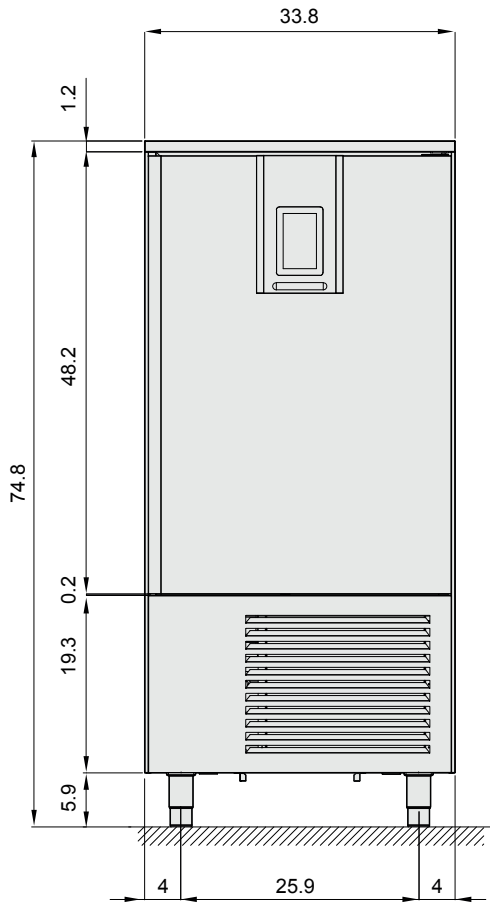

inch

S DRAINING WATER = 59 HOLES, INT. 17.5, L=1015mm



! Before handling the equipment, it is mandatory to read the safety warnings on the first pages of this booklet.

Transport

▶ Fig. 1

Transport the still packed equipment to the place chosen for installation using a forklift truck with a capacity greater than the weight of the equipment to be lifted: the operator of the forklift will be responsible for lifting the load. **The use of unsuitable equipment can lead to accidents to personnel carrying out the operation and/or damage to the equipment.**

Unpacking

▶ Fig. 2

Before unpacking, check that there are no visible damages. In the event of damage:

- prepare a photographic documentation of the damage;
- promptly notify the carrier/manufacturer.

If not, proceed to unpacking by removing the cardboard surrounding the equipment.

Also remove the protective film from the ovens avoiding the use of abrasive/aggressive substances or metal objects (e.g. scrapers).

! If any residue of adhesive remains, wipe with a soft cloth soaked in an oil-based, non-aggressive or abrasive detergent, suitable for stainless steel surfaces. Avoid using scrapers, abrasive or cutting tools.

 As potentially dangerous, packaging material must be kept out of the reach of children or animals and properly disposed of according to local regulations.

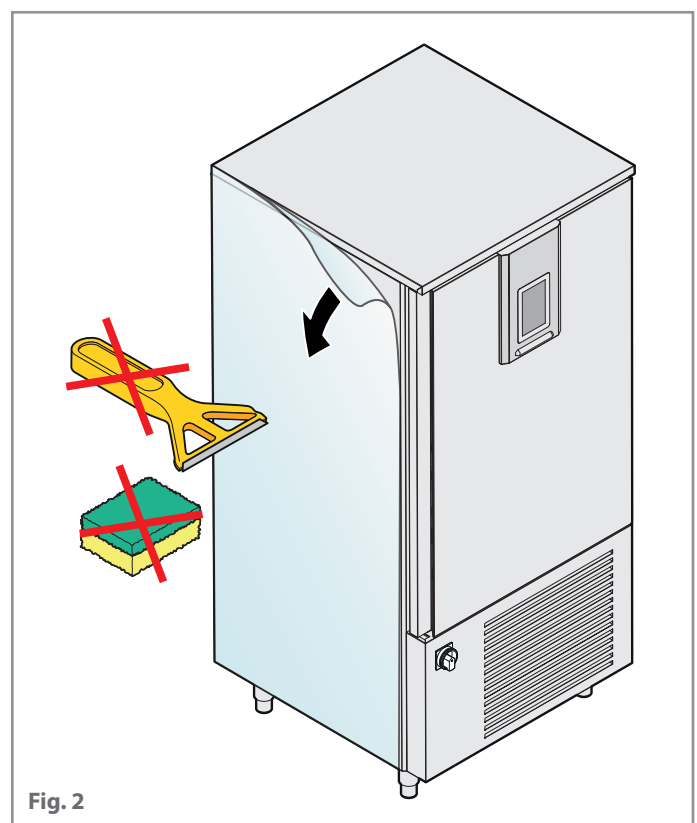
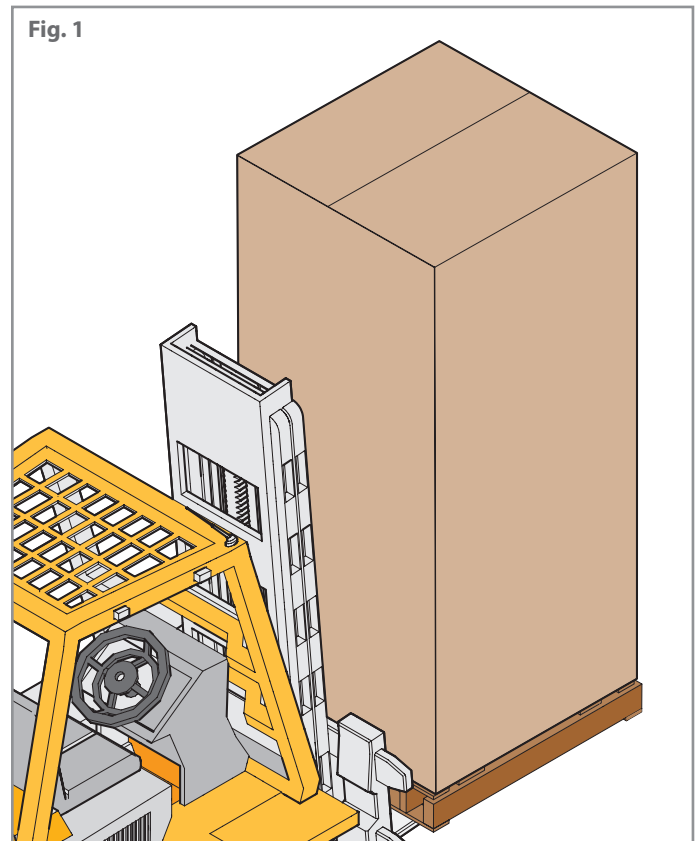

Checking the appliance

► Fig. 3

Check the integrity of the equipment, checking that it has not been damaged during transport and that all the components necessary for installation and use are present.

In the event of damage or missing parts:

- get the equipment data, present on the technical data plate;
- prepare a photographic documentation of the damage;
- promptly notify the carrier/manufacturer.

Handling after unpacking

► Fig. 4

To move the equipment fitted with wheels, simply push them, taking care to release the special brakes on the wheels themselves and to re-lock them when the appliance is placed in its final position.

To move equipment with feet, proceed with lifting it using an appropriate forklift; the forks must be placed under the equipment, taking care not to damage any part of it.



Fig. 3

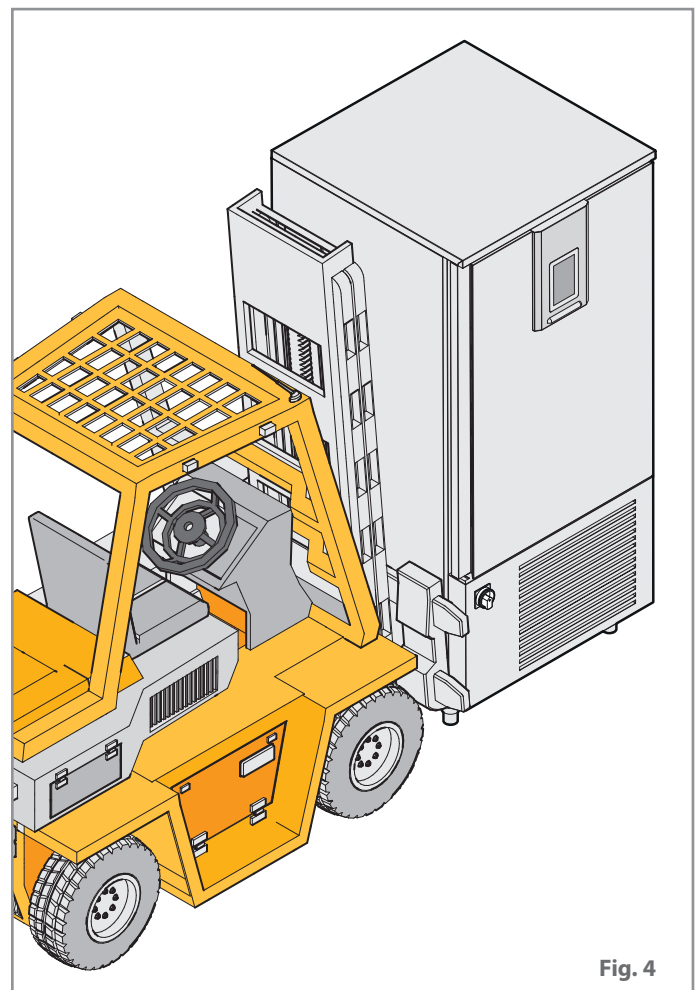

Fig. 4



! Before installing and connecting the equipment, it is mandatory to read the safety warnings on the first pages of this booklet.

Choosing the position

► Fig. 5

The positioning room must:

- be large enough to allow handling the equipment;
- be well ventilated and not exposed to the weather;
- have a temperature between 15°C/95°F and 40°C/104°F and humidity lower than 70%;
- have a floor without any roughness, perfectly levelled and capable of supporting the equipment at full load;
- have the electrical, water and refrigeration systems necessary for the connection that comply with current regulations in terms of safety at work and the systems themselves;
- have good natural or artificial lighting, suitable for the operations to be carried out (based on specific standards);
- be dedicated to preparing food.

► Fig. 6

Install the equipment:

- so as to have access to water and electricity connections;
- away from flammable and/or potentially explosive materials (e.g. gas cylinders);
- taking into account that the appliance door must be fully opened;
- so that it is perfectly level, if necessary act on the feet;
- keeping the safety distances shown in the figure.



! Positioning near other equipment that reaches high temperatures is not recommended. If it is necessary, provide a space of at least **50 cm/ 19.6 inch** on the side and **70 cm/ 27.6 inch** in the back or erect an insulating wall.

! Do not place the equipment near materials or containers of flammable material (e.g. partition walls, gas cylinders, etc.) due to the fire risk. Coat any walls with non-flammable thermal material. The equipment is not suitable to be built-in.

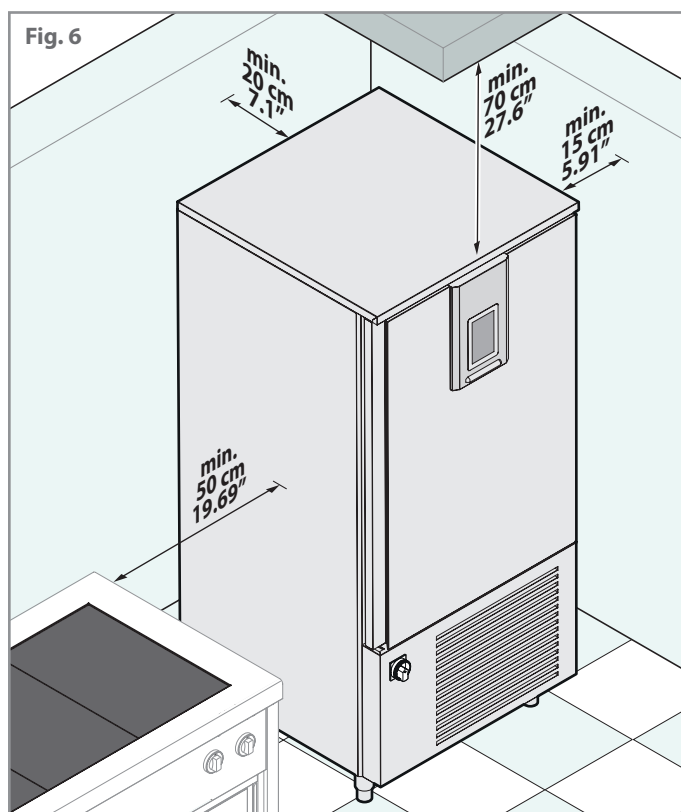
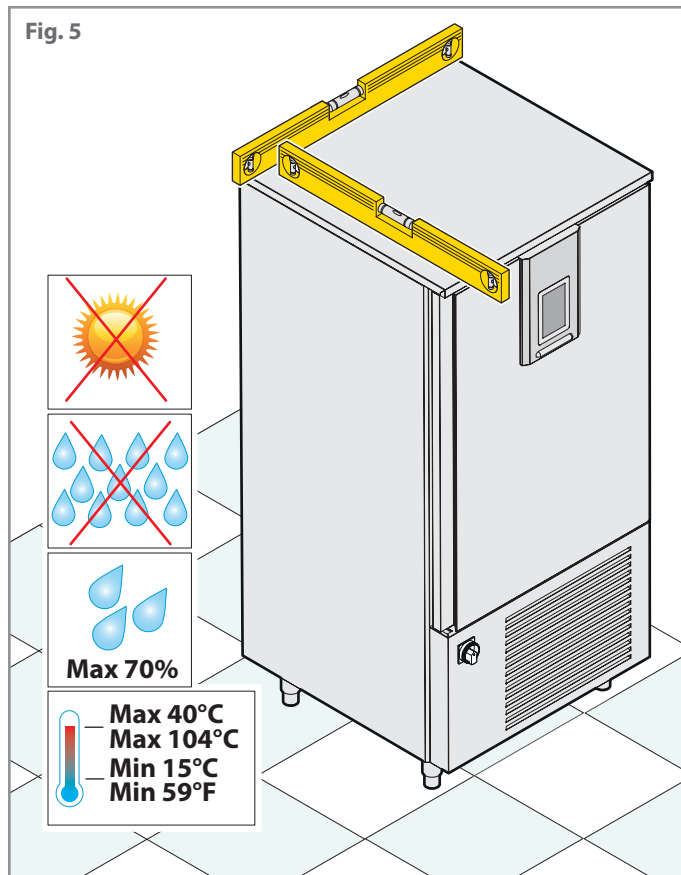
! When choosing the location room, take into account that the equipment must be easily moved for any extraordinary maintenance: take care that any masonry works subsequent to installation (e.g. construction of walls, replacement of doors with narrower ones, renovations, etc. ...) do not hinder movement.



Electrical connection

- 
The connection to the power supply network must comply with the regulations in force in the country of the equipment installation and must be carried out by a specialized electrician authorized by the Manufacturer. Failure to comply with these rules may cause damage and injury, void the warranty and release the Manufacturer from all liability.
- 
Before proceeding with the electrical connection, always compare the system data with those shown on the technical data plate.
- 
When the appliance is in operation, the value of the supply voltage must not differ by +/-10% of the value shown on the technical data plate.

Depending on the model, different electrical connections are required:

	BCT/05	BCT/10	BCT/15
	The equipment is supplied by the manufacturer complete with a power cord and plug. Connected the equipment to a power outlet in the installation's site  Fig. 7		The equipment is supplied with a power cord and is NOT supplied with a plug. A specialized electrician authorized by the Manufacturer must: A) fit a plug on the power cord or, alternatively B) remove the supplied electrical cable and connect a new electrical cable to own electrical panel
Supply voltage	1x115 Volt 60Hz plug NEMA 5-20P / 5-15P cable length 2.5 m [98.4"]	1x230 Volt ~ 60 Hz plug NEMA 6-20P / 6-15P cable length 2.5 m [98.4"]	3x230 Volt ~ 60 Hz

Make sure that the cable:

- has no tight kinks;
- is not crushed by objects or other equipment;
- is not in contact with sharp or hot objects;
- does not hinder the passage of people.

 Upstream, the equipment must be provided with an easily accessible **switch** installed in the system according to the regulations in force in the country of installation of the equipment. This switch must have an omnipolar contact separation so as to guarantee complete disconnection under overvoltage category III.

A correct **earth connection**  is mandatory and the earth cable must not be interrupted in any case by the protection switch. When there are several appliances in the same room, it is mandatory to provide an **equipotential connection** using the appropriate terminal marked with the symbol . This terminal allows you to connect an earth cable according to the current legal requirements. The effectiveness of the equipotential system must be properly checked according to what is stated in the current legislation.

If it is necessary to disconnect the power plug, first make sure that the card is positioned to OFF on the display. The manufacturer declines all responsibility for damage or accidents caused by failure to comply with these standards.

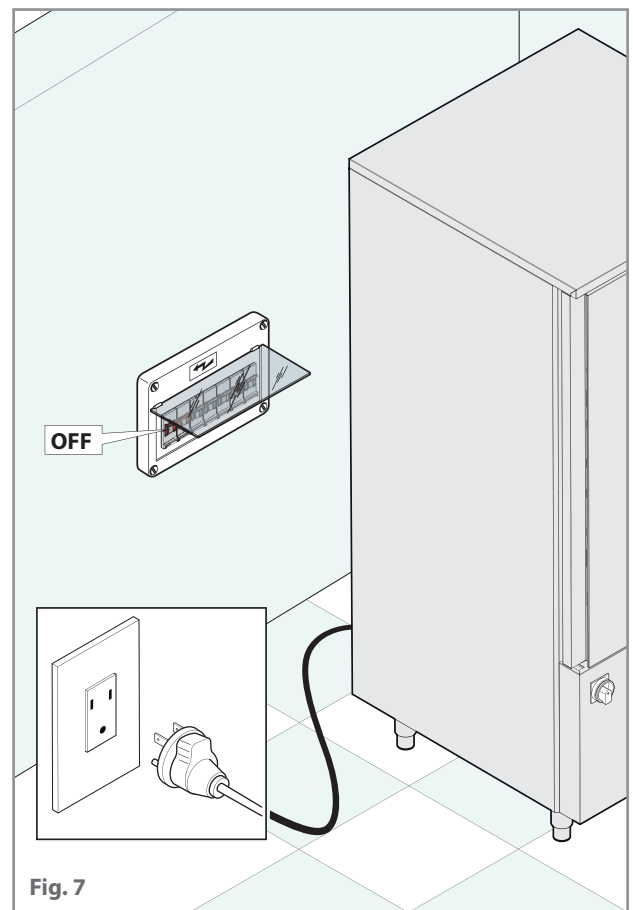

Fig. 7



Connection to the waste water network

► Fig. 8

The equipment leaves the factory equipped with a **GN 1/1 tray** placed under it which must be periodically checked, emptied and cleaned.

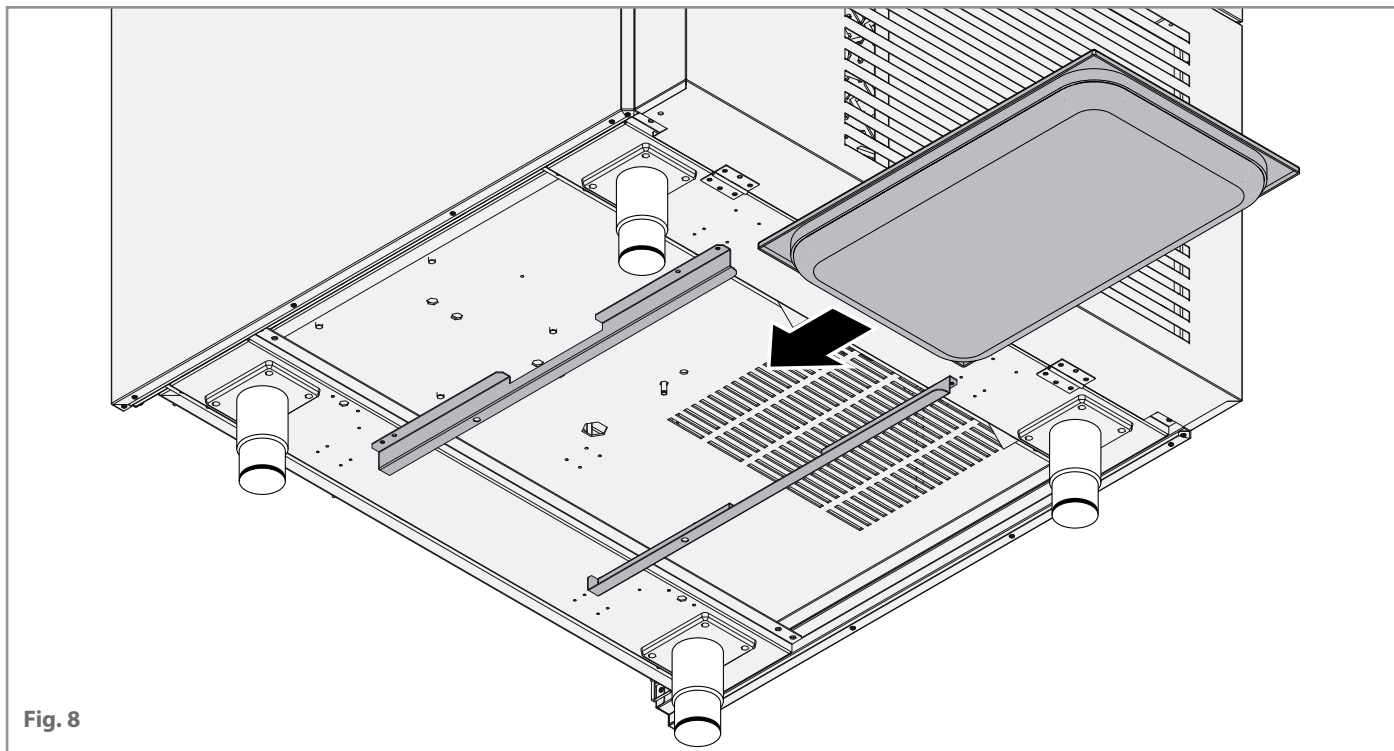

Fig. 8

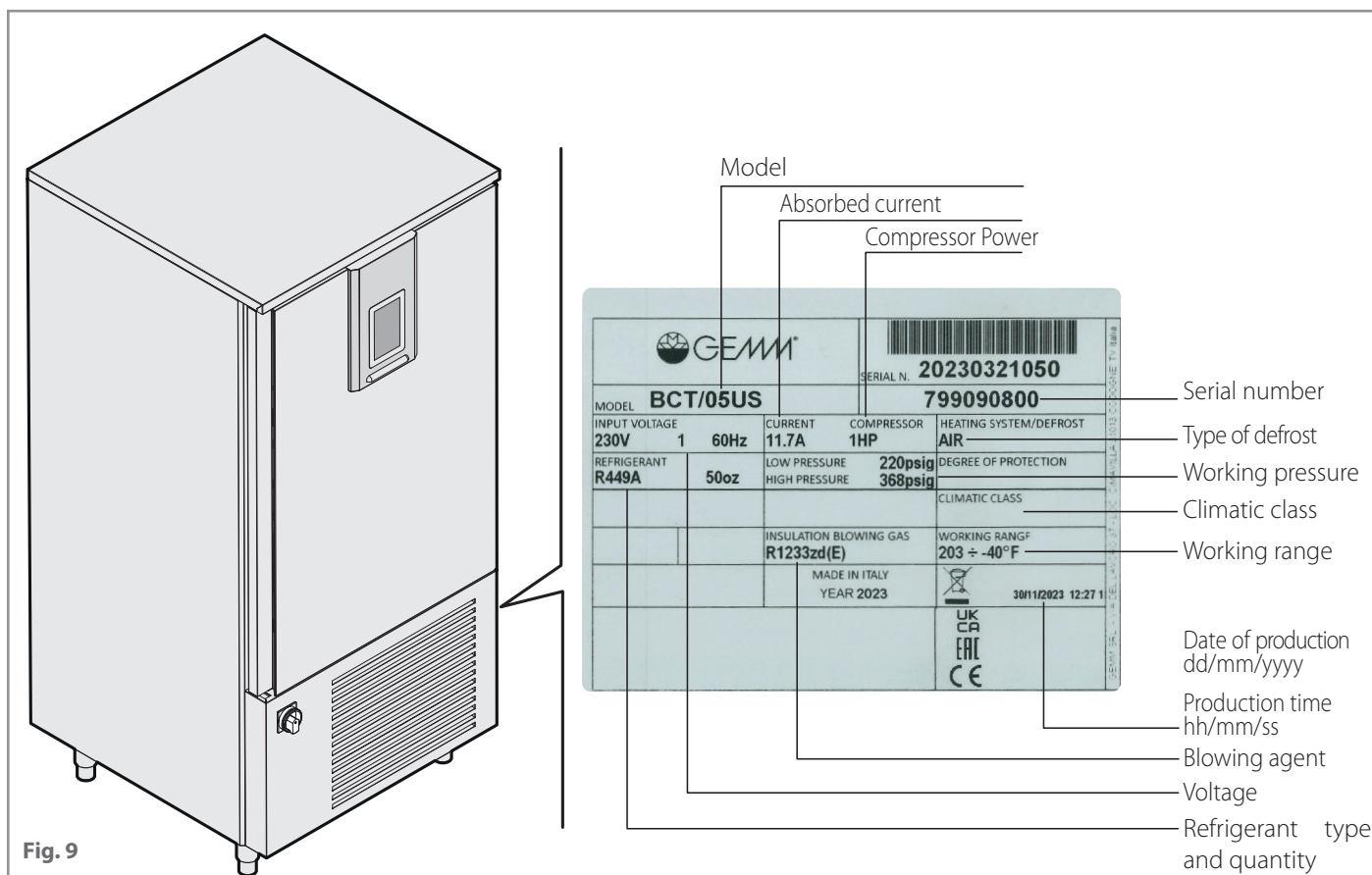



Fig. 9



! In R449A appliances there is a compressor oil heater, once the machine first starts the standby mode (main switch on and LED board off), it is necessary to wait at least 2 hours before starting a blast chilling cycle.

Final checks

Positioning checks	YES	NO
Was the adequacy of the installation rooms checked (minimum/maximum temperature, etc ...)?		
Is the appliance perfectly level?		
Have the minimum distances from walls (15 cm/5,9 inch) and from other equipment (50 lateral) been complied with?		
Has the protective film been removed from all surfaces?		
Is the equipment perfectly intact, with no visible damage?		
Is the inside of the equipment free of non-compliant objects (booklets, plastic bags, etc ...)?		
Electrical checks	YES	NO
Do the characteristics of the network comply with the data found on the technical data plate?		
Was the electrical connection made according to the regulations in force in the country of installation of the equipment by a skilled electrician authorized by the Manufacturer?		
Is the equipment provided with a correct earth connection  (the earth cable must in no case be interrupted by the protection switch)?		
Is the equipment connected to an equipotential system?		
Is there an easily accessible switch upstream of the equipment?		
General checks	YES	NO
Does the door close correctly?		
Does the compressor turn off when the appliance reaches the set temperature?		
Does the user have all the necessary documentation? Has he been correctly trained on the use of the machine?		

INSTALLER'S STAMP AND SIGNATURE

PURCHASE INVOICE

Date.....Number

APPLIANCE DATA (FROM DATA PLATE)

Model:

Serial number (Ser. No.):

CUSTOMER DETAILS

Name and Surname:

Company name:

Address 1:Address 2:.....

Town:Province:.....

INSTALLER DETAILS

Name and Surname:

Company name:

Address 1:Address 2:.....

Town:Province:.....

Tel/Email:



USE

Preliminary knowledge	22
Knowing the appliance.....	22
Protection devices.....	24
How to get the best from the appliance.....	25
Arranging the food inside the cell.....	25
Maximum load table.....	25
Carrying out scheduled maintenance.....	25
Using the needle probe correctly.....	25
Use	26
Switching on.....	26
Keypad lock/unlock.....	27
Silencing the acoustic signal.....	27
Door open warning.....	27
Setting the language, date and time.....	27
Blast chilling/freezing.....	28
Setting and starting a blast chilling/freezing cycle.....	28
Blast chiller	28
Saving a cycle with the desired parameters.....	30
Modifying a cycle parameters.....	31
Continuous cycle.....	32
Customized cycle.....	33
Pre-cooling	34
Recipe book	36
Modifying a recipe and saving it with another name.....	37
Fish sanitization.....	38
Special cycles	38
Thawing.....	39
Defrosting.....	39
Sterilization.....	39
Ice cream hardening.....	39
Drying.....	39
Recipe download/upload.....	40
Parameter download/upload.....	40
Parameter download/upload.....	40
USB	40
Ordinary maintenance	42
Scheduling the cleaning.....	42
Cleaning the internal cell and external parts.....	43
Cleaning the condenser.....	43
Cleaning the needle probe.....	44
Downtime.....	44
Disposal.....	45
After-sales service	46
Warranty.....	46



 **Before using the appliance, it is mandatory to read the safety warnings listed in the first pages of this booklet.**

Knowing the appliance

 **Fig. 10**

The blast chiller is an appliance with a powerful refrigeration system capable of **rapidly lowering the core temperature** of food. Its use is ideal in any kitchen, bakery and ice cream parlour.

The appliance consists of the following components:

- 1** appliance body;
- 2** condensing unit (only for equipment with integrated unit);
- 3** evaporating unit (only for equipment with integrated unit);
- 4** control panel;
- 5** stop function.

The work cycles that the machine can carry out are:

- **BLAST CHILLING** ▶ Positive blast chilling (3°C/37°F). The freshly baked product is brought to a temperature of 3°C/37°F in a short time, thus inhibiting bacterial proliferation and avoiding dehydration by evaporation of the cooked product. The product thus treated can be perfectly stored for 5-7 days without altering its organoleptic qualities. The **HARD** function is used when the product to be cooled is large in size (thickness greater than 2-3 cm / 0,7-1,1 inch) or is particularly fatty. The equipment develops variable air temperatures to accelerate the penetration of the cold into the product.
- **FREEZING** ▶ Negative blast chilling (deep freezing) (-18°C/0°F). This work cycle allows to quickly bring the core of the product to a temperature of -18°C/0°F. The speed of the process avoids the formation of macro crystals ensuring that, at the time of final use, the thawed food has the original consistency, colour and quality. The **SOFT** function is used when the product to be cooled is particularly delicate.
- **STORAGE** ▶ At the end of each cycle, both positive and negative blast chilling, the appliance will automatically adopt the expected storage temperature.

Each blast chilling (both negative and positive) provides **two different end cycle modes** after which storage begins:



temperature execution end: the cycle ends when the needle probe inserted in the core of the product reaches the set temperature;



timed execution end: the cycle ends when the set time is reached.



This blast chiller is not an equipment suitable for the indefinite storage of food.



DANGER OF FROSTBITE: during its work phases, the appliance can manage very low temperatures, avoid direct contact with the internal parts of the machine immediately after opening the door.

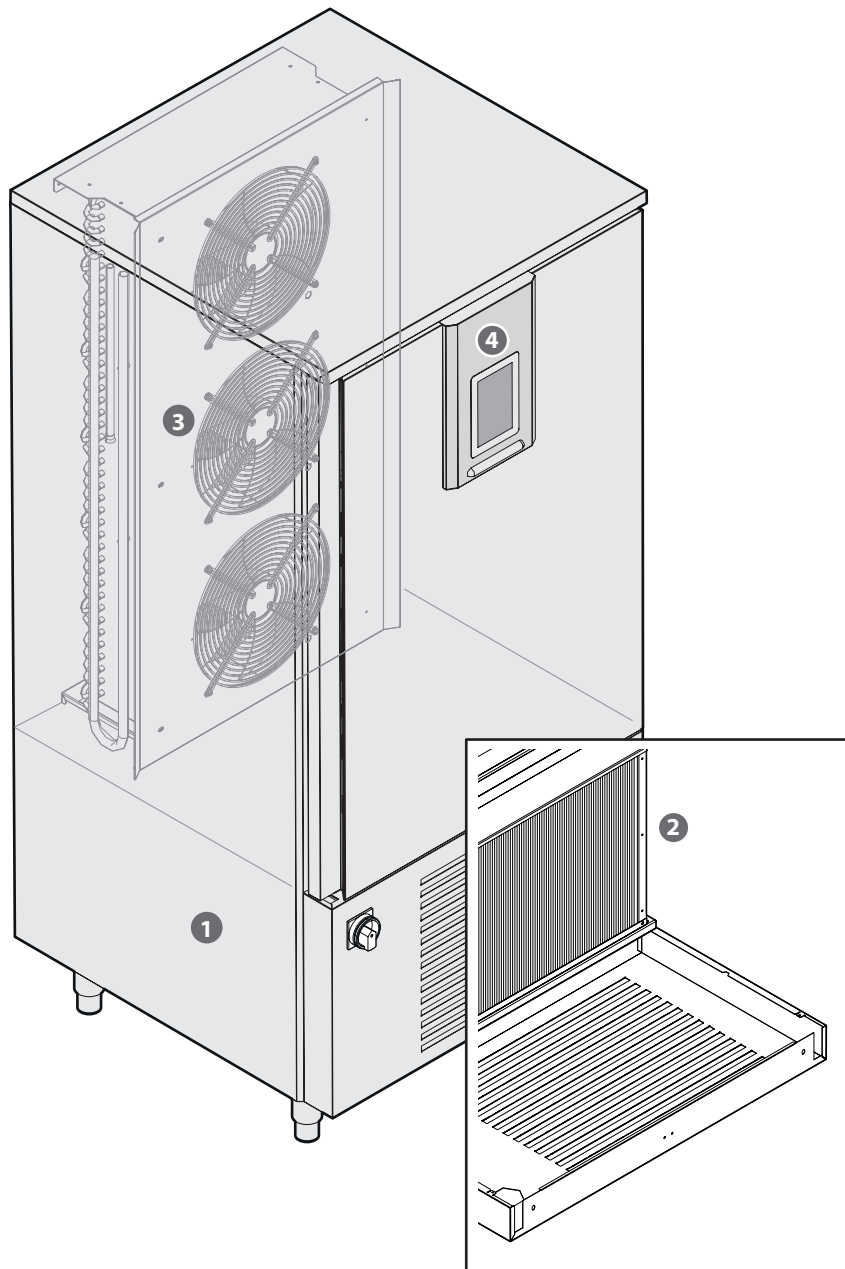

Fig. 10



Protection devices

► Fig. 11

The protection of the personnel exposed to the risks due to dangerous mobile elements is guaranteed by the presence of suitable devices on the appliance:

- 1 grilles covering the cooling fans;
- 2 grille covering the condensing unit;
- 3 sensor located on the cooling circuit: signals any system overheating and pressure by putting the machine on standby;
- 4 sensor that detects and signals the opening of the door. If the door remains open for a time longer than a pre-set parameter, the icon will appear on the display, an acoustic signal will sound and then the compressor will shut down.

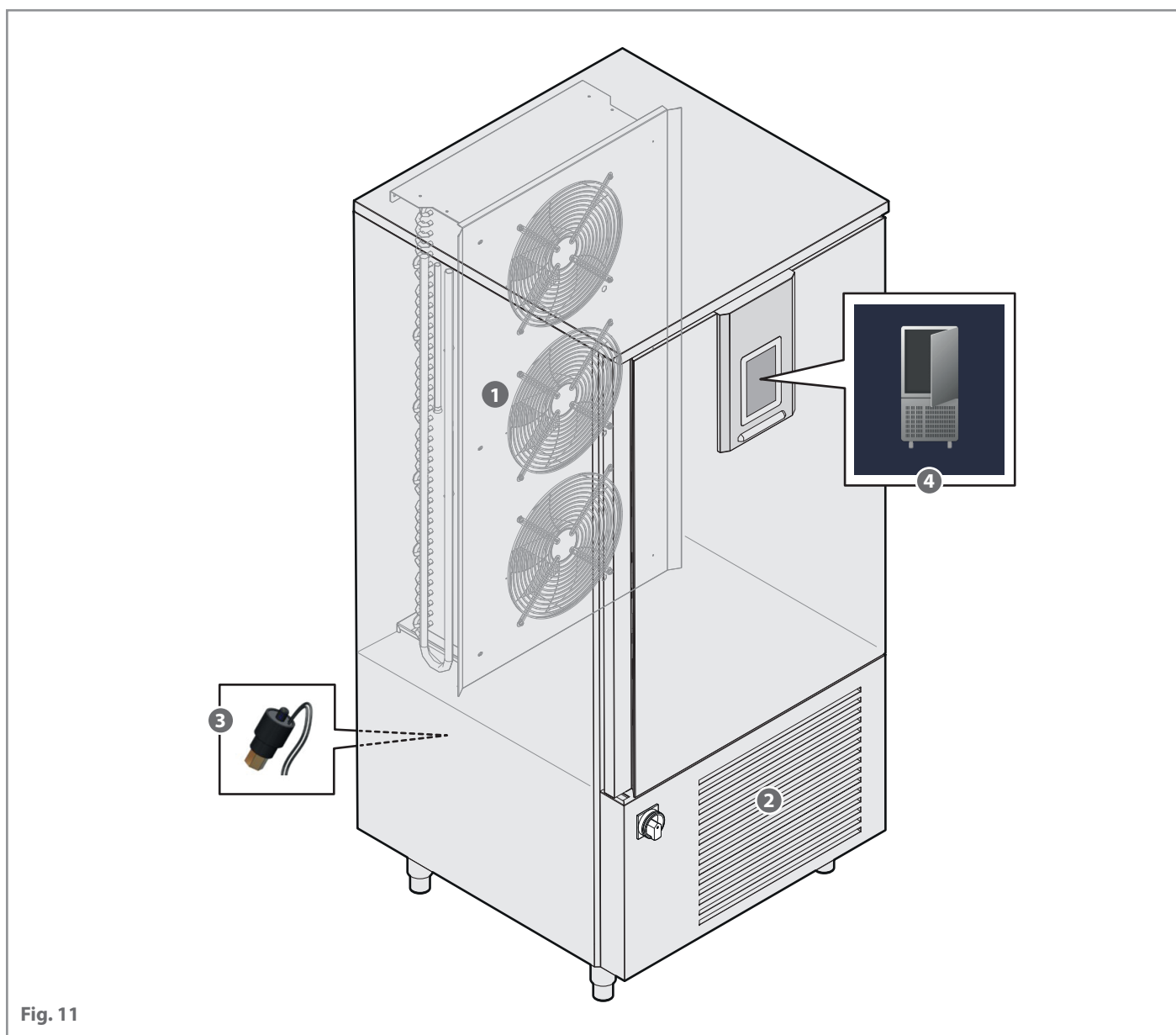

Fig. 11

How to get the best from the appliance

Arranging the food inside the cell

The foods to be chill blasted must be placed, in a single layer, in containers with low edges and suitable for food use.

Arrange them homogeneously and evenly inside the cell.

Correct positioning of the containers will allow the free circulation of air inside the latter: avoid obstructing the ventilation fans and overloading the equipment beyond the permitted limits.

Maximum load table

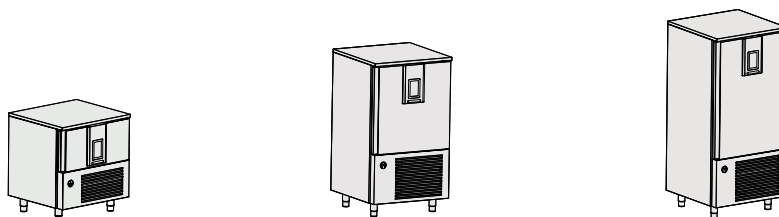

Model		BCT/05 US	BCT/10 US	BCT/15 US
Tray capacity	No.	5 18"x26" (cm 66x46) or GN 1/1	10 18"x26" (cm 66x46) or GN 1/1	15 18"x26" (cm 66x46) or GN 1/1
Internal cell temperature	°C / °F	+95/-40 °C / +203/-40 °F		
Load capacity	kg	+3°C ÷ +65 = 20 Kg +65°C ÷ -18°C = 12 Kg	+3°C ÷ +65 = 37 Kg +65°C ÷ -18°C = 24 Kg	+3°C ÷ +65 = 68 Kg +65°C ÷ -18°C = 49 Kg
	lbs	+37°F ÷ +149°F = 44 lb +149°F ÷ +0°C°F = 26 lb	+37°F ÷ +149°F = 81.5 lb +149°F ÷ +0°C°F = 53 lb	+37°F ÷ +149°F = 150 lb +149°F ÷ +0°C°F = 108 lb

Carrying out scheduled maintenance

Regular and correct maintenance ensures optimal performance and a longer life of the equipment.

► see chapt. "Ordinary maintenance" on page 42.

Using the needle probe correctly

The needle probe, during blast chilling, detects the temperature at the "heart" of the food: when it reaches 3°C/ 37°F or -18°C/ 0°F, the cycle ends (if selected with a needle probe and not timed).

The needle probe must be inserted deeply into the food to be blast chilled: make sure that its tip reaches the "core" of the food, that is, its innermost point, without coming out. Be careful not to stick it in very fat spots or close to the bones.

If the food is not very thick, insert the probe parallel to the support surface.

We recommend you always keep the probe clean and sanitized.

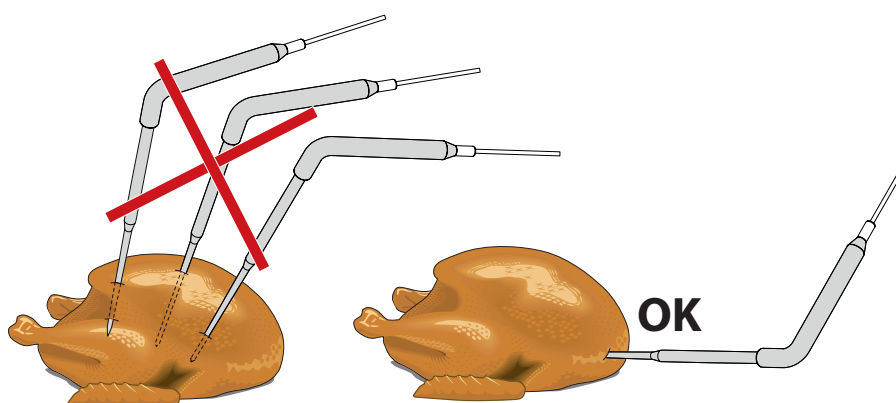



Fig. 12



! Before using the appliance, it is mandatory to read the safety warnings listed in the first pages of this booklet.

Switching on

► Fig. 13

- 1 Connect the power supply of the appliance.
- 2 The device will display a loading screen (LOADING...) for a few seconds.
- 3 A stand-by screen opens; press the  button to access the HOME PAGE screen.
- 4 From the HOME PAGE screen you can select the desired function:



Allows you to select the **blast chiller** mode, where you can select or set a blast chilling or deep freezing cycle.

► see page 28



Allows you to select the **special cycles** mode

► see chapt. 38



Allows you to select the **recipe book** mode, where factory-set and personal recipes are available.

► see page 36



Allows you to activate a **cell pre-cooling** cycle.

► see page 34

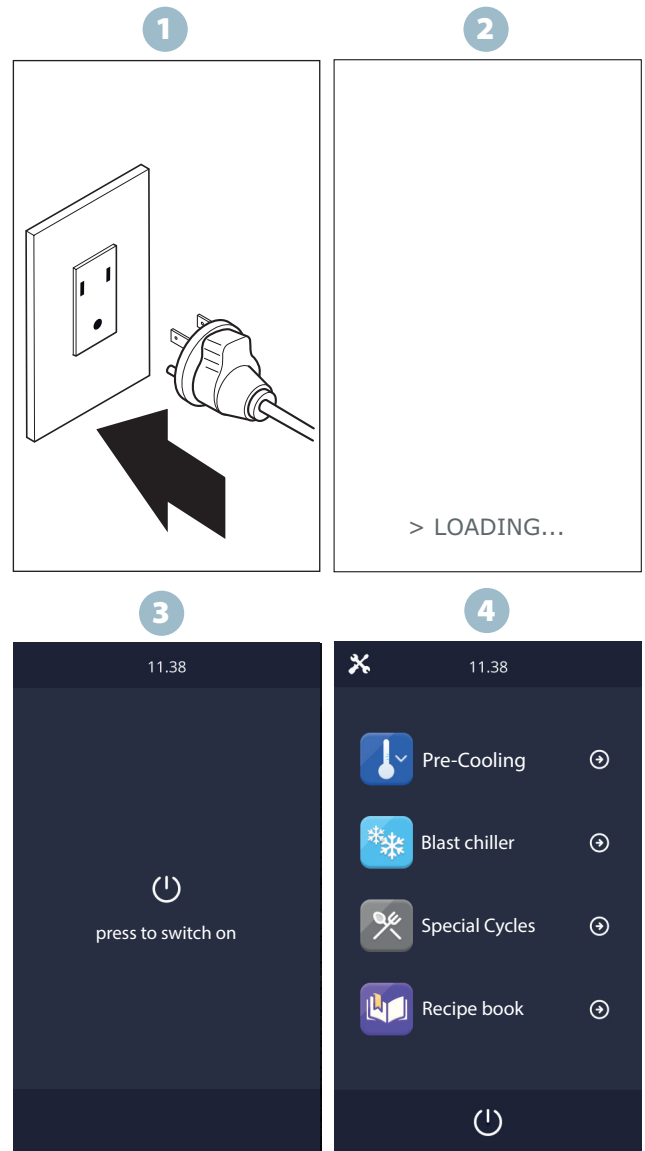

Fig. 13

The symbols on the screen also provide useful information:



alarm in progress



pressing the symbol allows you to view the historical data recorded during operation



returns to the stand-by function

Keypad lock/unlock

► Fig. 14

The keyboard is locked after a certain factory-set inactivity time: a message appears on the screen and any operation is prevented. To unlock it, drag the slider sliding your finger to the right.

Silencing the acoustic signal

To silence the acoustic signal, touch any area of the display while the sound is in progress.

Door open warning

When the door is opened, the alarm message appears on the display. Touch any area of the display to get rid of the message.

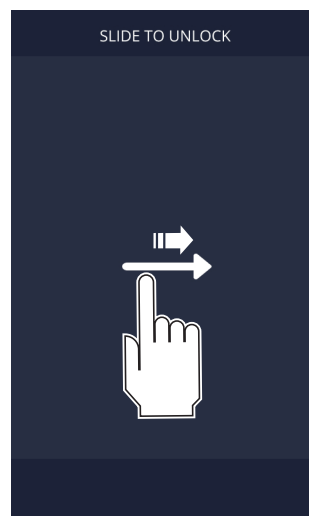

Fig. 14

Setting the language, date and time

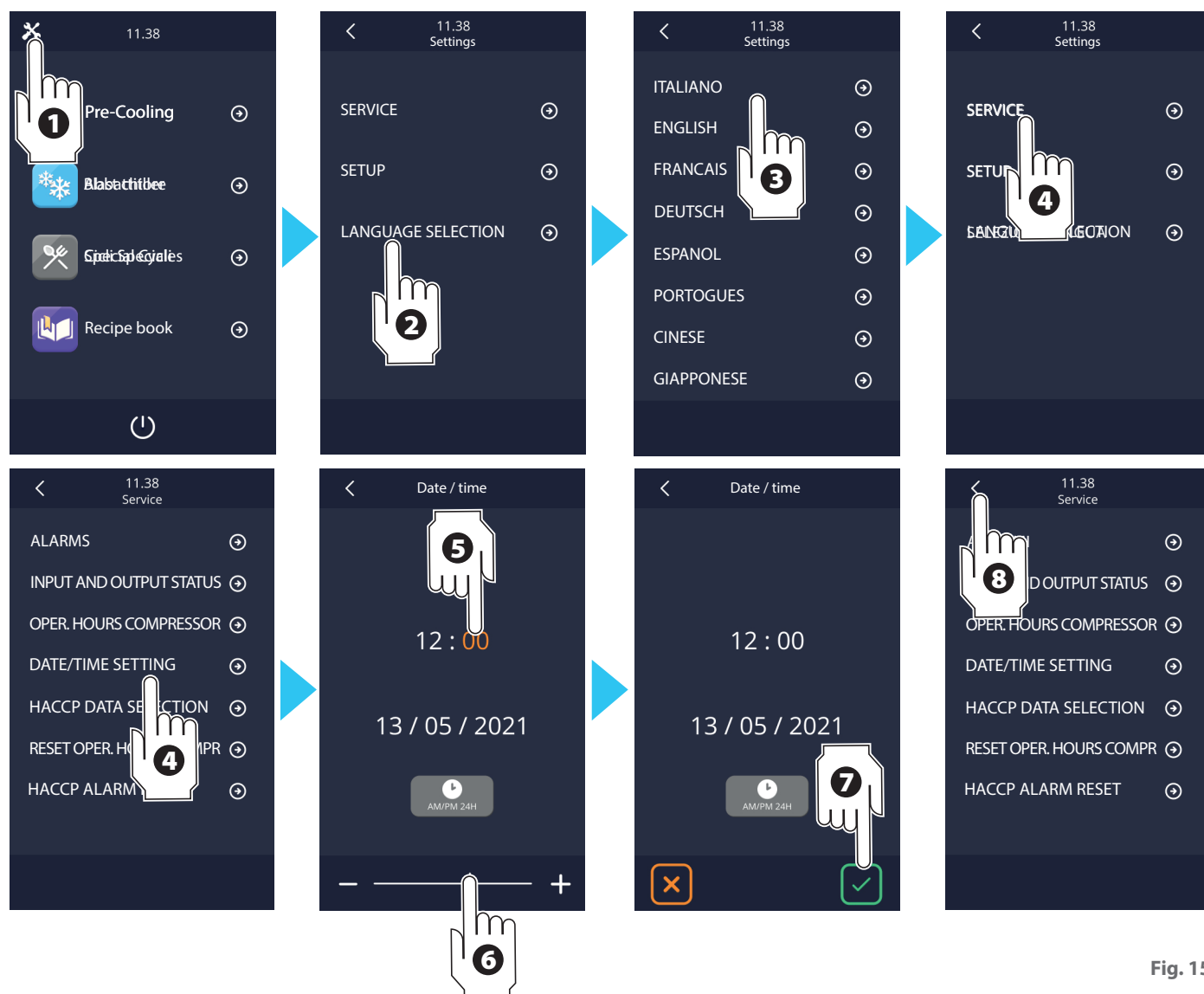

Fig. 15



Blast chiller



Blast chilling/freezing

In **blast chiller** mode you can choose between two different cycles:

POSITIVE BLAST CHILLING

► **+3°C/+37°F**

The freshly baked product is brought to a temperature of 3°C/ 37°F in a short time, thus inhibiting bacterial proliferation and avoiding dehydration by evaporation of the cooked product. The product thus treated can be perfectly stored for 5-7 days without altering its organoleptic qualities.

NEGATIVE BLAST CHILLING (DEEP FREEZING)

► **-18°C/ 0°F**

This work cycle allows to quickly bring the core of the product to a temperature of -18°C/0°F. The speed of the process avoids the formation of macro crystals ensuring that, at the time of final use, the thawed food has the original consistency, colour and quality.

Setting and starting a blast chilling/freezing cycle

► Fig. 16

1 Select the desired cycle (blast chilling +3°C/37°F or deep freezing -18°C/0°F). Both cycles consist of a blast chilling/deep freezing phase, followed by a storage phase which, if not interrupted, has an infinite duration.

2 The display shows the settings of the phase of the chosen cycle:



temperature to be reached in the cell



timed cycles: cycle duration in minutes



cycles with needle probe: temperature that the probe must reach to end the cycle



fan speed

3 Choose if you wish to set a cycle with needle probe ("PROBE" icon) or a time one ("CLOCK" icon):



...the cycle ends when the **needle probe** detects that the temperature of the core it is inserted in has reached +3°C/37°F (blast chilling) or -18°C/0°F (deep-freezing). This mode is recommended so you can be certain that the food has been properly blast chilled.



...the cycle ends after the set **time** rather than when the core temperature is reached: the default duration is 90 minutes but it can be changed as you wish ► See chapt. "**Modifying a cycle parameters**" on page 31.
The two modes (needle probe and time) are mutually exclusive).

In the same screen you can:

3a ...make changes to the pre-set parameters (e.g. change the fan speed)



► See chapt. "**Modifying a cycle parameters**" on page 31.

3b ...select the **HARD** (it is used when the product to be blast chilled is large or particularly fat) or **SOFT** function (delicate deep-freezing).



Both cycles consist of two blast chilling phases with different parameters and a subsequent storage phase.

- 1st phase ("hard" for blast chilling and "soft" for deep freezing) with modifiable parameters;

- 2nd blast chilling/deep freezing phase with modifiable parameters;

- 3rd storage phase with modifiable parameters.

The end of a phase is signalled by an acoustic signal, then it automatically passes to the next. Also for this cycle it is possible to select the time mode: in this case the passage to the next phase is given by the expiry of the time.

3c ... access settings reserved for expert personnel.

- 4 Press the **"SUMMARY"** key: a summary screen of the parameters of the blast chilling and storage phases relative to the selected cycle is displayed: moreover, if parameters have been modified, it is possible to check them.
- 5 Close the door and press the **"START"** button to start the cycle (be careful, if you use a cycle with needle probe, remember to insert it in the food to be blast chilled). If the cycle uses a needle probe, a test is performed to verify the correct insertion of the same into the food to be blast chilled: if the test is not passed, the cycle automatically switches to timed mode: an acoustic signal starts and the display shows the symbol of the alarm in progress.



Before starting the cycle, if changes have been made to the parameters, it is possible to save the cycle with the new settings.

► See **chapt. "Saving a cycle with the desired parameters" on page 30**



During the execution of a cycle, the temperature values of the enabled probes, the activations of the outputs, the status of the inputs, the execution of the defrost cycles and the presence of any alarms are recorded. These data are available for subsequent download with a USB device.

► See **chapt. USB on page 40**

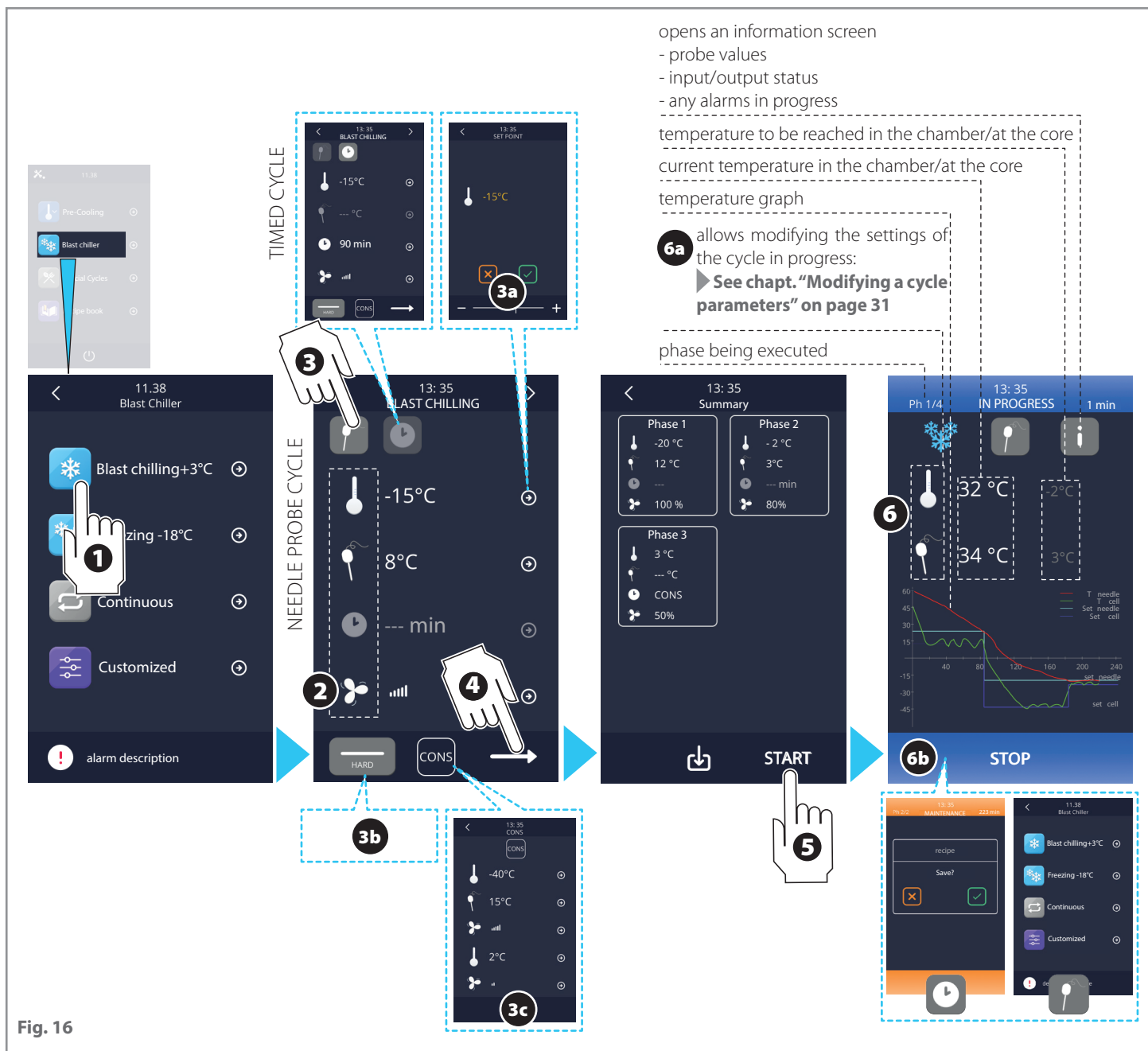

Fig. 16



▶ Fig. 16

- 6 The cycle in progress screen appears.
During the cycle in progress it is always possible to:
 - 6a change the settings of the phase in progress ▶ See chapt. “Modifying a cycle parameters” on page 31.
 - 6b block the cycle before its effective end by pressing the “STOP” button: if the cycle was timed, the initial screen will be displayed, if the cycle was with needle probe, the possibility is given to save the recipe.

Once the blast chilling/deep freezing cycle has ended, because the temperature of the needle probe has been reached or because the time has expired, an acoustic signal is emitted and the storage phase begins which, if not interrupted, has an infinite duration.

! If the cycle with the needle probe does not end within the time set in the factory, the anomaly will be signalled by the presence of the alarm icon, but the blast chilling cycle will continue anyway. A cause might be overloading the appliance beyond its loading limits ▶ See chapt. “Maximum load table” on page 25.

Saving a cycle with the desired parameters

If changes have been made to the parameters of a cycle that is then started (“START”), the changes made will have an effect only on the cycle in progress: this means that once the cycle is finished, if you reuse it, it will not have the changes made earlier. For this reason it may be better to **save** the modified cycle so that you can reuse it every time you wish to. ▶ Fig. 17

- 1 Modify a cycle parameters as explained in chapt. “Modifying a cycle parameters” on page 31.
Touch the “SUMMARY” button to display the parameters of all the cycle phases.
- 2 Touch the “SAVE” button.
- 3 Touch the position where you want to save the modified cycle. If you select a position already occupied, a screen appears asking for confirmation before overwriting the recipe.
- 4 Touch “✓” to confirm the insertion of a new name.
- 5 Enter the desired name and touch and 6 confirm the entered name.

To start a saved cycle, access the “Recipe book” - “my recipes” section, select its name and press the “START” button.

 Do you want to set up a completely customized cycle, using up to 4 phases?
▶ See chapt. “Customized cycle” on page 33

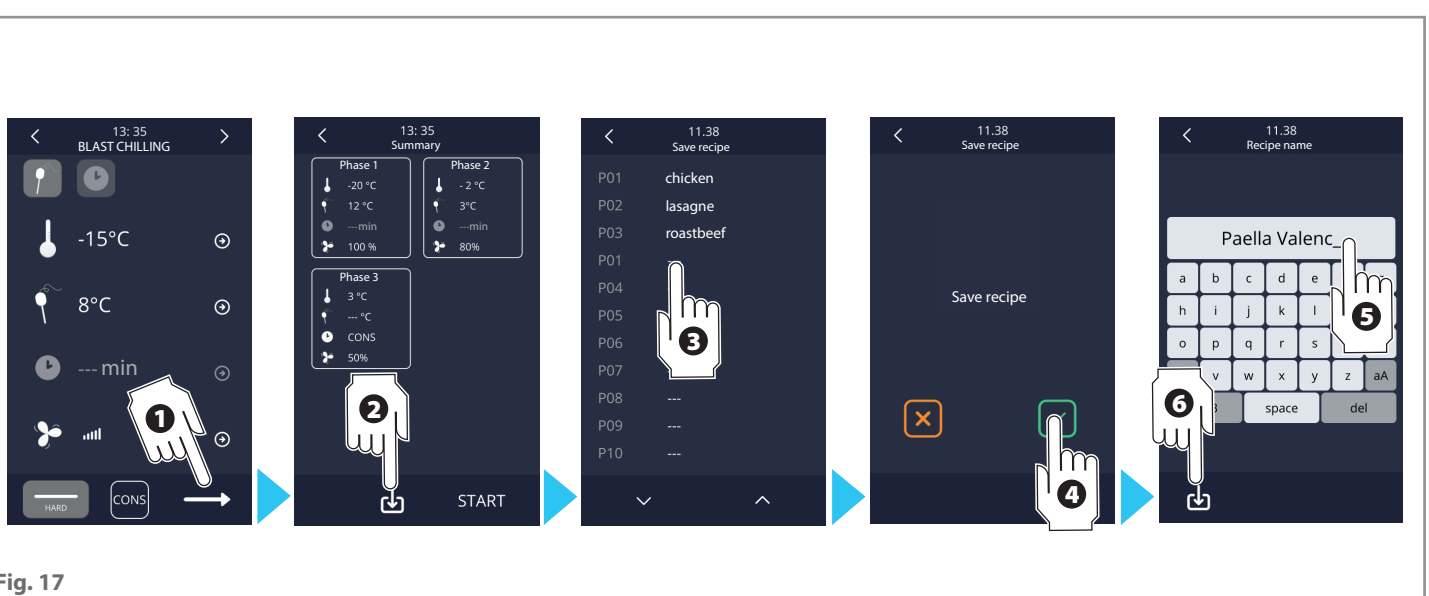

Fig. 17

Modifying a cycle parameters

The modification of the parameters of a cycle can be carried out before starting the cycle or during its execution.

In both cases the changes are **temporary**, that is, they only apply to the cycle that will be started or that is in progress.

If you want the changes made to be permanent, you must save the cycle with a name of your choice: in this way you can reuse it as many times as you want.

► See chapt. "Saving a cycle with the desired parameters" on page 30

► Fig. 18

- 1 Touch the "PENCIL" symbol corresponding to the parameter you wish to modify (*in the example the cell temperature is to be modified*).
- 2 Act on the symbols "+" or "-" or drag the cursor to enter the desired value within the expected range.
- 3 Touch "✓" to confirm or "✗" to exit the screen without saving.



Fig. 18



Continuous cycle

The **continuous cycle** function is useful when you want to blast chill/freeze at the same time foods that have different processing times. The foods must be inserted into the cell **all at the same time**; an acoustic signal and a message on the display will warn when it is time to remove a food from the cell as it has been blast chilled.

The end of the cycle can be managed:

- using up to three needle probes ▶ a signal will be given when each probe detects that the set temperature has been reached;
- setting up to 4 timers ▶ a signal will be given when the time set for each timer has expired.

▶ **Fig. 19**

- 1 Place the foods into the cell: if you decide to use the needle probes (up to three), insert them into the food: choose three different sizes, e.g. one in a small piece, one in a medium one, one in a large one.
- 2 Select the "continuous cycle" function.
- 3 Touch the "**PROBE**" or "**CLOCK**" symbol to select blast chilling with the needle probe (ends when the probe detects the set temperature) or timed (ends at the end of the set time).
- 4 Touch the "**SUMMARY**" button.
- 5 Set the desired probe temperatures or times (up to three probes and up to 4 timers are available): the countdown of the timers or the probe temperature measurements start immediately, without needing to perform any other operation.
- 6 7 A food has reached the expected core temperature or its timer has expired; the temperature or the timer turn green, an acoustic signal and a message warn that it can be taken from the cell while the others continue processing **without the need for any other operation**. The cycle ends only when all the needles have reached the set temperature, when all the timers have expired or if the "**STOP**" key is pressed, afterwards it automatically passes to the storage phase.

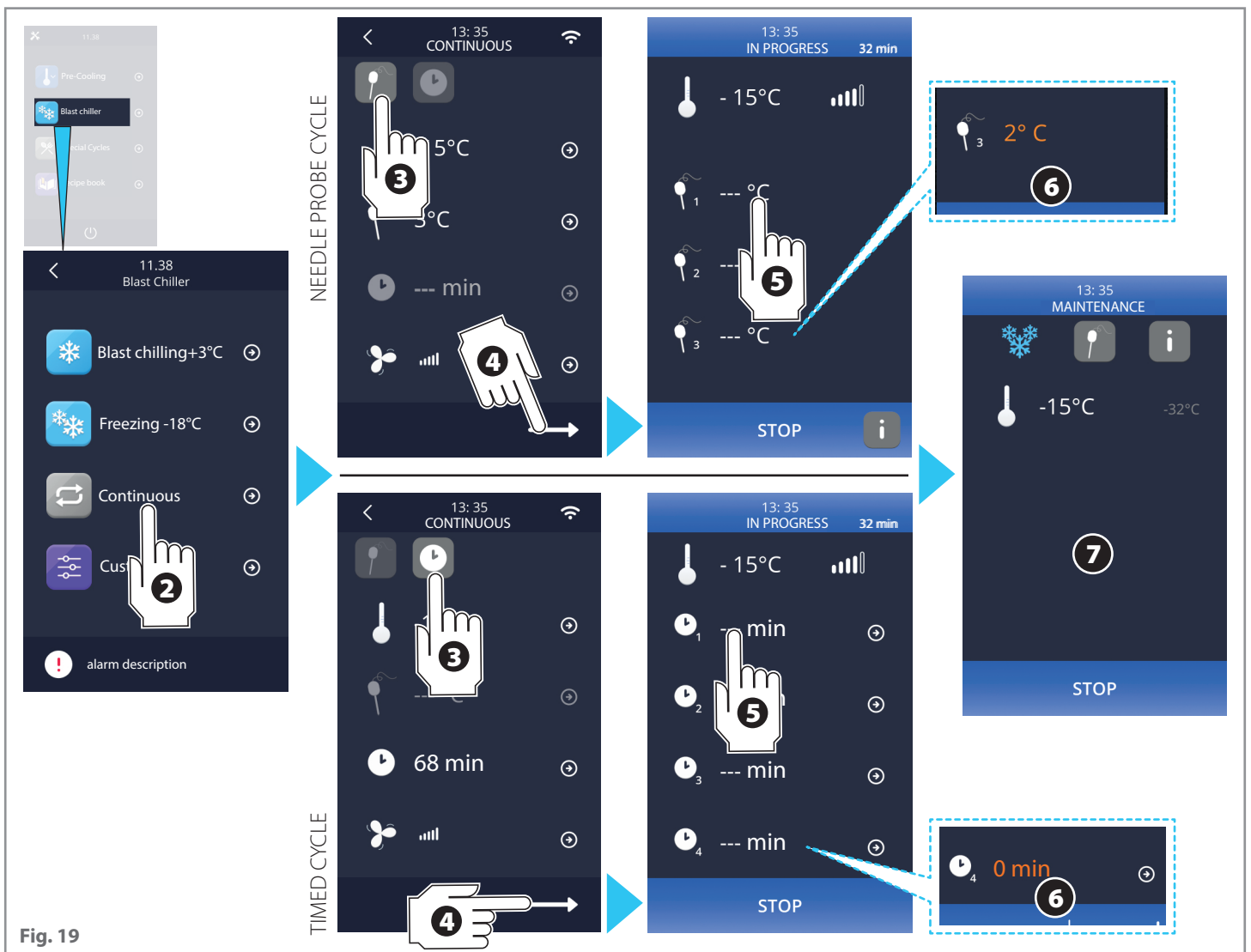

Fig. 19



Customized cycle

The **customized cycle** function allows you to set a cycle consisting of a maximum of 3 blast chilling/deep freezing phases plus a storage phase. The phases can all be with needle probe, all timed or mixed.

To start a saved customized cycle, access the **"Recipe book" - "my recipes"** section, select its name and press the **"START"** button.

► Fig. 20

- 1 Select the "customized cycle" function: the 1st phase of the cycle appears.
 - 2 3 Touch the **"PROBE"** or **"CLOCK"** symbol to select blast chilling with the needle probe (ends when the probe detects the set temperature) or timed (ends at the end of the set time).
- Make the desired changes as explained in **chapt. "Modifying a cycle parameters" on page 31.**
- 4 If you want to add other phases, touch the **"ADD"** symbol and modify them as you did for the 1st phase. To pass to the setting of the storage phase from the 3rd phase, it is necessary to touch the **"SUMMARY"** key.
 - 5 Touch the **"SUMMARY"** key: a summary of all the set phases is displayed.
 - 6 It is now possible to save the set cycle or to start it pressing the **"START"** key: in this last case the settings made will not be saved. The saved customized cycles are found in the **"Recipe book" - "my recipes"** section.

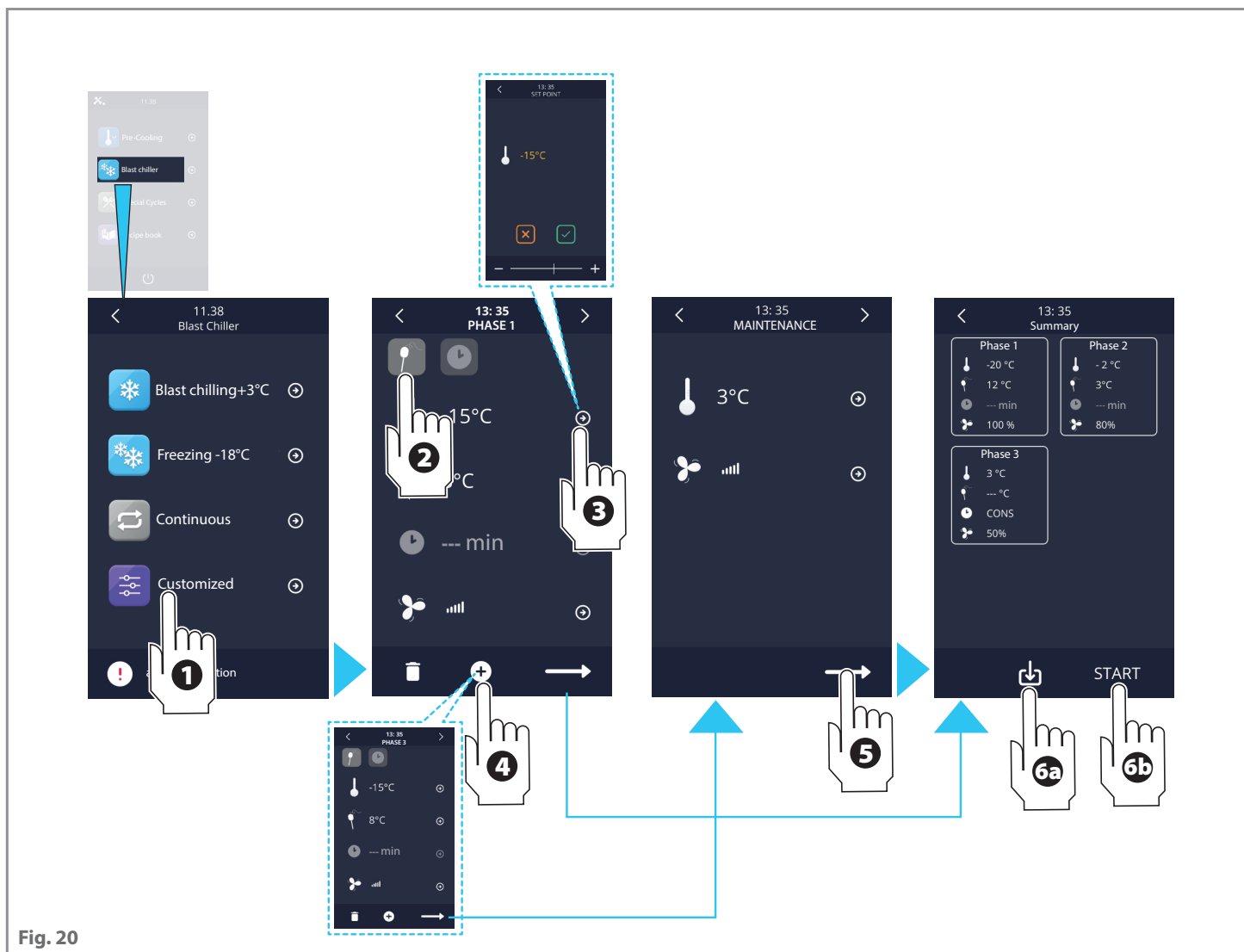

Fig. 20



With this section it is possible to select a cell **pre-cooling** cycle: in this way the foods will be blast chilled/deep frozen in faster times and with better results.

Pre-cooling is a cycle similar to normal blast chilling, which can precede all operating cycles.

Fig. 21

- 1 Touch the "PRE-COOLING" symbol.
- 2 Act on the symbols "+" or "-" or drag the cursor to enter the desired value within the expected range.
- 3 To proceed, touch the temperature displayed on the screen or the arrow on the side.
- 4 Touch "START" to start the procedure.

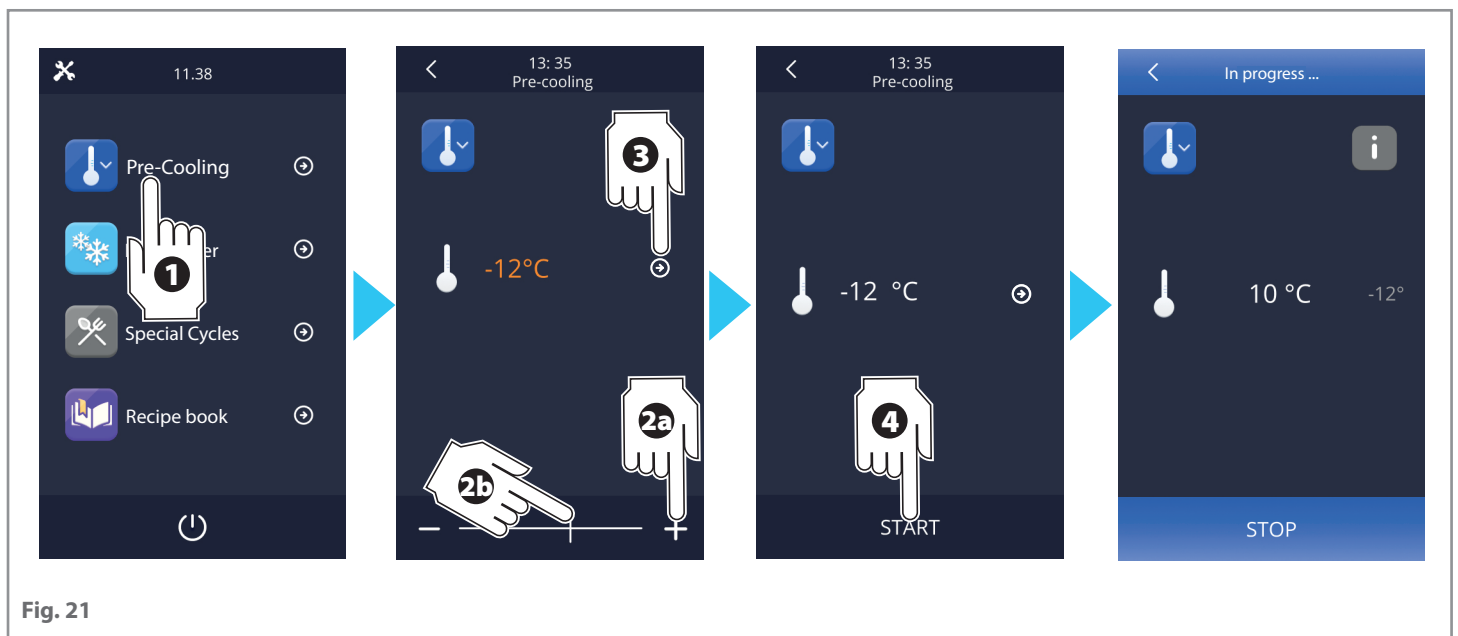

Fig. 21



This section contains all the recipes, both those set at the factory and the user's personal ones.

Fig. 22

- 1 Touch the "RECIPE BOOK" symbol.
- 2 Choose the section where the recipe you want to use is (blast chilling, deep freezing, my recipes).
- 3 Choose the type of recipe you want.
- 4 Start the recipe pressing the "START" key.

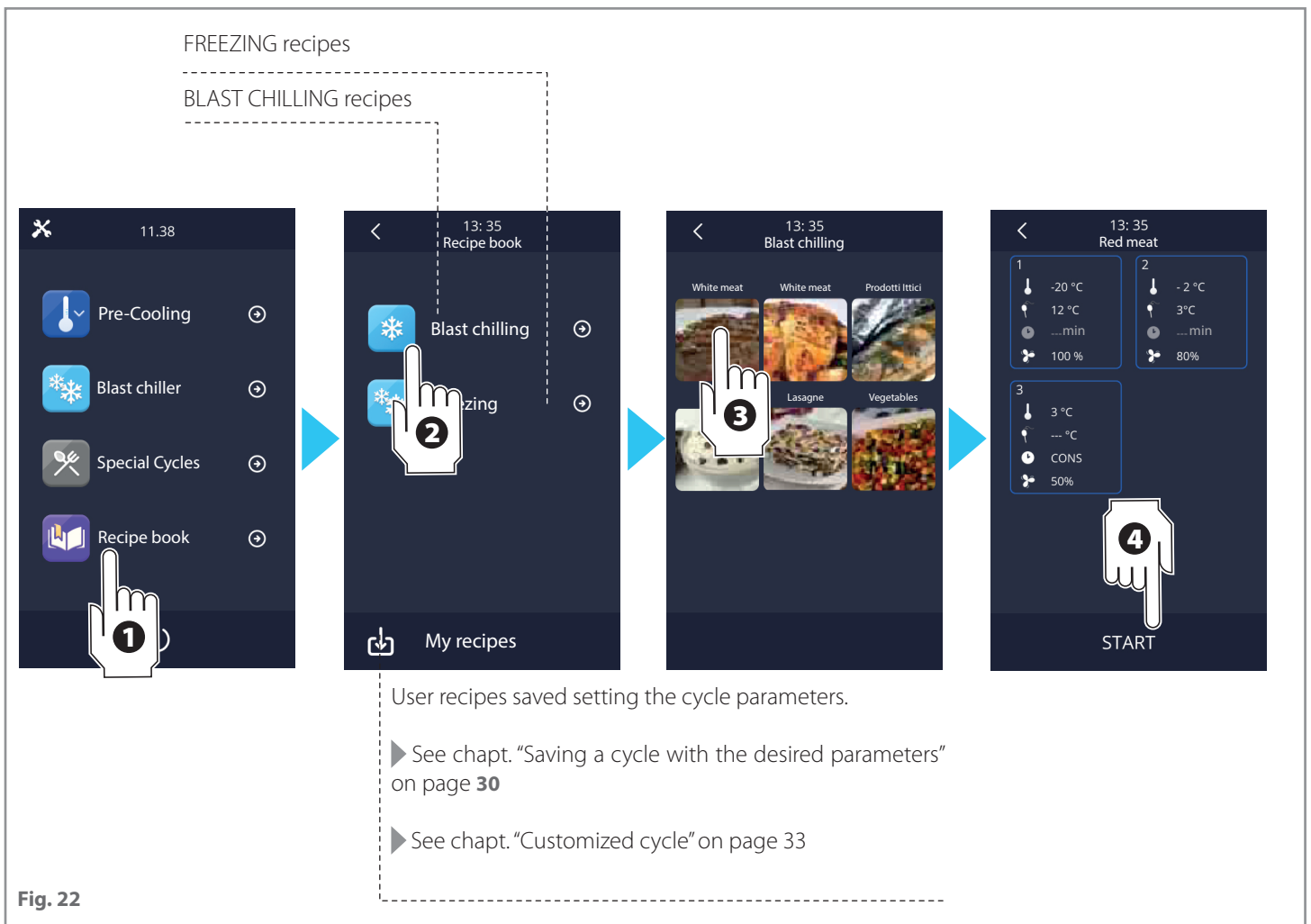

Modifying a recipe and saving it with another name

It is possible to modify an already stored recipe and store it with a new name and with the new settings (the original recipe is not deleted or modified).

► Fig. 23

- 1 Touch the "RECIPE BOOK" symbol.
- 2 Choose the section where the recipe you want to modify is located (blast chilling, deep freezing, my recipes).
- 3 Choose the type of recipe you want.
- 4 Touch the phase to be changed (*in the example we want to change the parameters of PHASE 2*).
- 5 Touch the "PROBE" or "CLOCK" symbol to select blast chilling with the needle probe (ends when the probe detects the set temperature) or timed (ends at the end of the set time).
- 6 Make the desired changes as explained in **chapt. "Modifying a cycle parameters" on page 31**.
- 7 Press the "<" symbol.
- 8 Make further changes in other phases or touch the "SAVE" key.
- 9 Touch the position where you want to save the modified recipe. If you select a position already occupied, a screen appears asking for confirmation before overwriting the recipe.
- 10 Touch "✓" to confirm the entered name. 11 Enter the desired name and touch and 12 confirm the entered name.

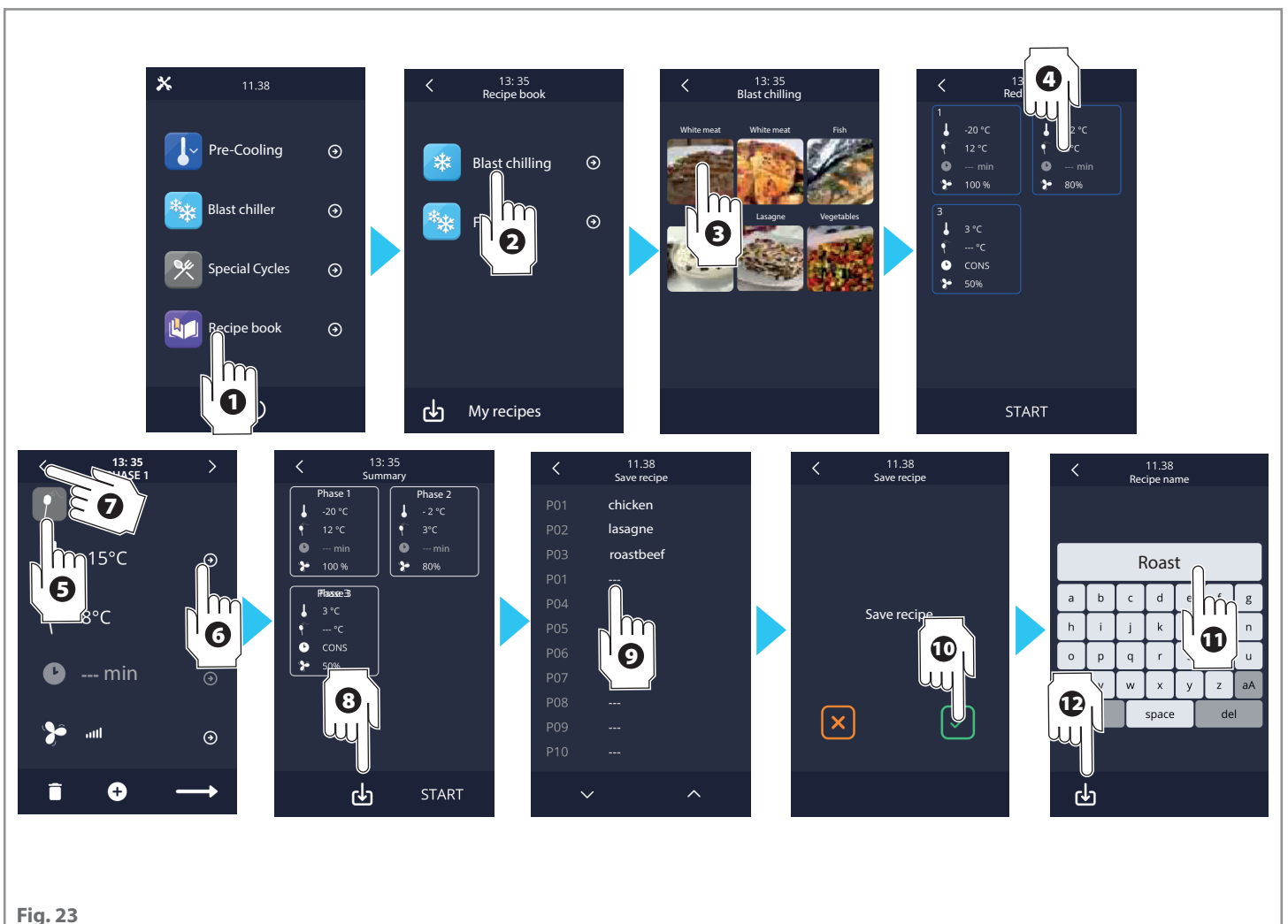

Fig. 23



Special cycles



In this section you have access to special cycles that facilitate normal work operations.



Fish sanitization

Sanitizing fish products is very important as this procedure guarantees the inhibition of the *Anisakis simplex* bacteria which could be present in raw or cooked fish.



Anisakiasis is a parasitic infection of the gastrointestinal tract caused by the ingestion of raw or undercooked fish products containing the larvae of *Anisakis simplex*: if the larvae penetrate the gastric mucosa they cause violent abdominal pain, nausea and vomiting. If, a week or two after the infection, they manage to pass into the intestine, an important immune response can occur, with intermittent abdominal pain, nausea, diarrhoea and fever or intestinal perforation.

The sanitization cycle begins with a **blast chilling** phase: when the temperature detected by the needle probe reaches the end of blast chilling temperature, the device will automatically go to the next phase, **maintenance**. Once the time set for maintenance has elapsed, the device automatically switches to **storage**.

► Fig. 24

- 1 2 3 Pressing the ">" symbol several times, the parameters of all three phases that can be changed can be viewed ► see **chapt. "Modifying a cycle parameters" on page 31.**
- 4 Start the sanitization pressing the "START" key.
If necessary, it is possible to block the cycle before its end by pressing the "STOP" button:

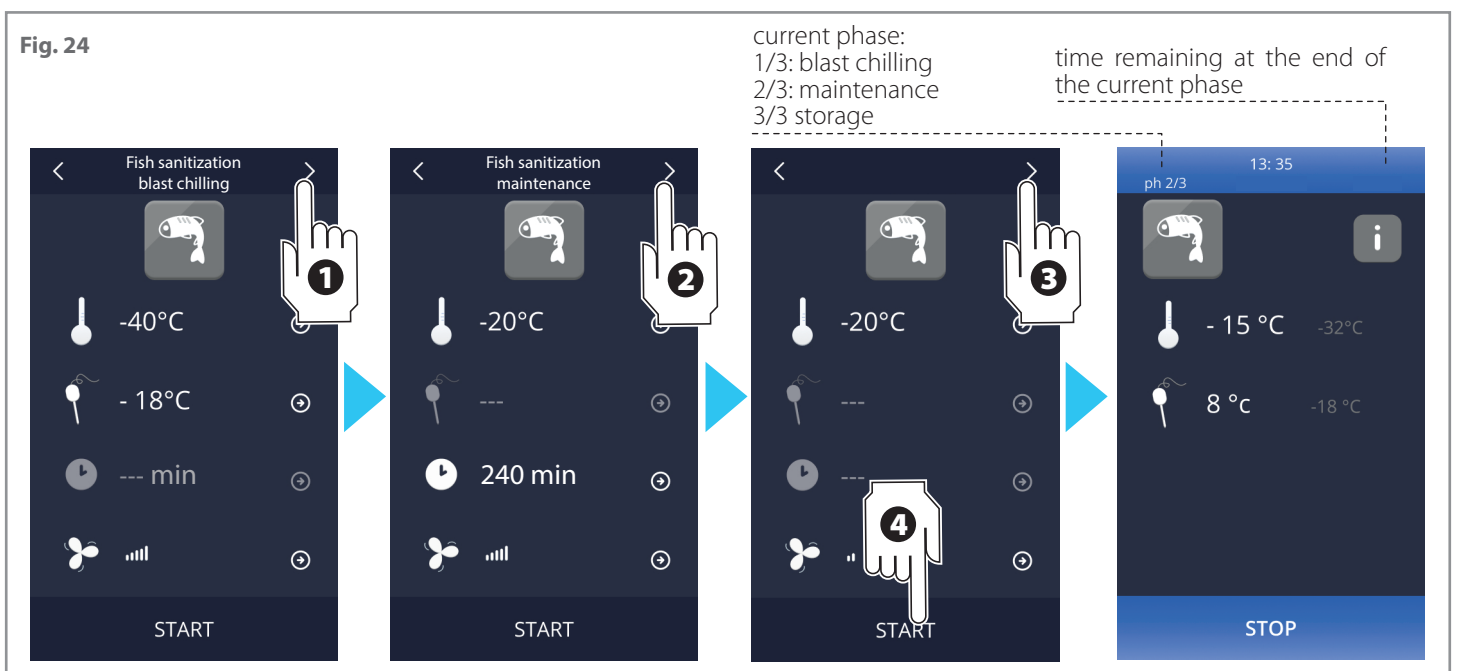

Thawing



The **thawing** function allows you to bring frozen products back to a positive temperature in a controlled and very rapid manner, in compliance with HACCP standards. This translates into a lower bacterial load and subsequent better cooking of the thawed food as the possibility of having parts of the food not fully cooked is reduced.

► **Fig. 25**

Thawing is managed by the equipment based on the load of the equipment you intend to do: low, medium, high (maximum quantity declared by the manufacturer). Once the thawing cycle is finished, an acoustic signal is emitted and the conservation phase starts which, if not interrupted, lasts indefinitely.

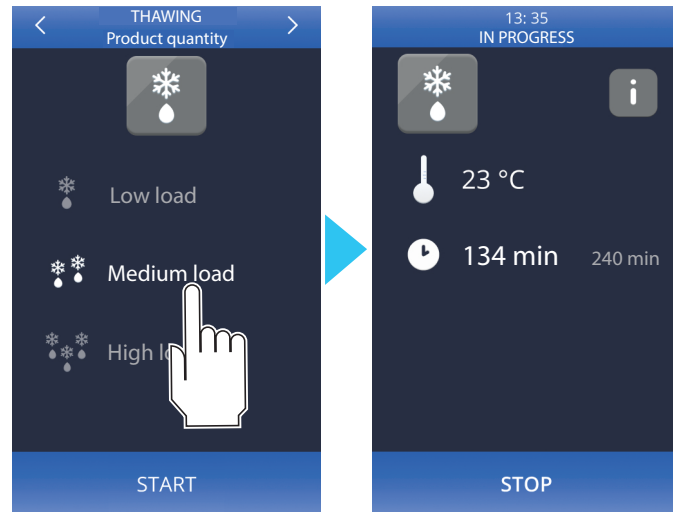

Fig. 25

Defrosting

► **Fig. 26**

Defrosting is carried out automatically at regular intervals but, if necessary, with this function it is possible to start a manual defrosting cycle.

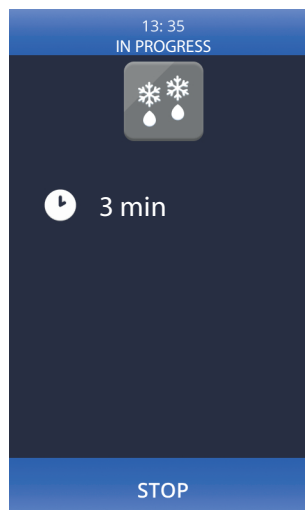

Fig. 26

Sterilization

► **Fig. 27**

The function starts a sterilization cycle of the cell, as long as the door is closed and the needle probe detects a temperature higher than 0°C. The display, for the entire duration of the function, shows the time left to the end (signalled by an acoustic signal).

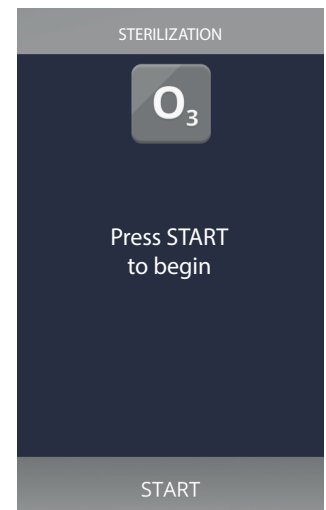

Fig. 27

Ice cream hardening

► **Fig. 28**

The function allows a freezing cycle particularly suitable for hardening the mass of ice cream. The hardening cycle, at the end of the set time, does not provide for a conservation phase but has an infinite duration which must be blocked by pressing the "stop" button. The end of the time is however signalled by an acoustic signal.



It is possible to change the cycle parameters as explained in the **chapt. "Modifying a cycle parameters" on page 31.**

Drying

The function starts a drying cycle by means of ventilation. The function is interrupted when the time runs out or by pressing the "STOP" key.

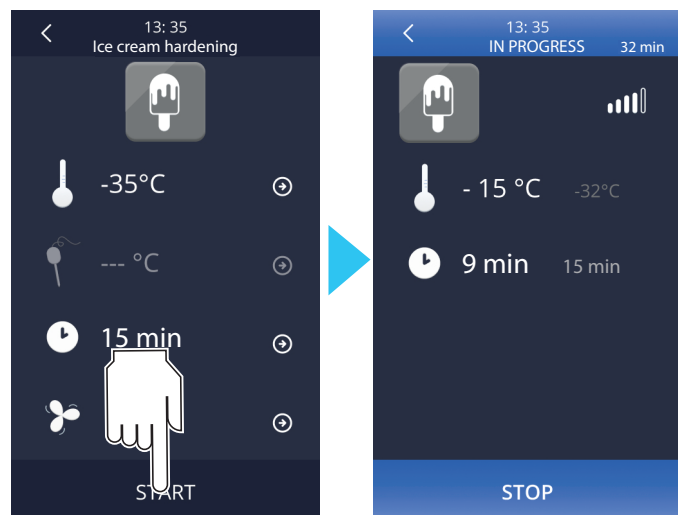

Fig. 28



The following operations can be performed through the USB port:

- downloading and uploading recipes;
- downloading and uploading configuration parameters;
- downloading information related to HACCP history.

To access these functions, turn off the panel and connect the USB stick to the port (**Fig. 29**).

The screen will be displayed **Fig. 30**

Recipe download/upload

Connect the USB stick and select **"DOWNLOAD RECIPES"** or **"UPLOAD RECIPES"**: the requested procedure will be automatically started; the writing/reading operation can take a few minutes. When finished, remove the USB stick from the serial port.

Parameter download/upload

Connect the USB stick and select **"DOWNLOAD PARAMETERS"** or **"UPLOAD PARAMETERS"**: the requested procedure will be automatically started; the writing/reading operation can take a few minutes. When finished, remove the USB stick from the serial port.

Parameter download/upload

Connect the USB stick and select **"DOWNLOAD HACCP DATA"**: a screen appears where you can select the start **date** and **time** of the log recording (touch day/month/year/time which turns green and can therefore be edited using the **"+"** and **"-"** keys to get the desired value).

Once confirmed, a CSV (Comma Separated Values) document will be automatically written onto the stick.

The writing operation can take a few seconds; at the end of the operation, remove the USB stick from the USB serial port.



Fig. 29

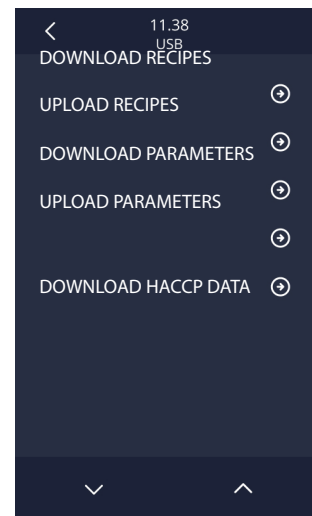

Fig. 30



Fig. 31



! Before carrying out any ordinary maintenance, it is mandatory to read the safety warnings on the first pages of this booklet.

Fig. 32

The only maintenance by the operator is the ordinary cleaning of the equipment. The manufacturer must be contacted for any anomaly or doubt encountered during the cleaning operations not described in this manual. For extraordinary maintenance (e.g. replacement of damaged parts, repairs, etc...) contact a Service Centre requesting the intervention of an authorized technician.

! Any cleaning operation must be carried out only after **switching the appliance off by acting on the display and disconnecting the plug**: any operation performed on the machine with the electrical system on can cause serious accidents, even fatal, to people.

! Any cleaning operation must be carried out after **wearing appropriate personal protective equipment** (e.g. gloves, etc ...).

! The manufacturer does not accept any warranty damage that is the result of lack of maintenance or incorrect cleaning (e.g. use of unsuitable detergents).

! To clean **any part of the equipment DO NOT** use:

- abrasive or powder detergents;
- aggressive or corrosive detergents (e.g. hydrochloric/muriatic or sulphuric acid, caustic soda, etc ...). Attention! Do not use these substances even to clean the floor under the appliance;
- abrasive or pointed tools (e.g. abrasive sponges, scrapers, steel brushes, etc ...);
- jets of steam or pressurized water.

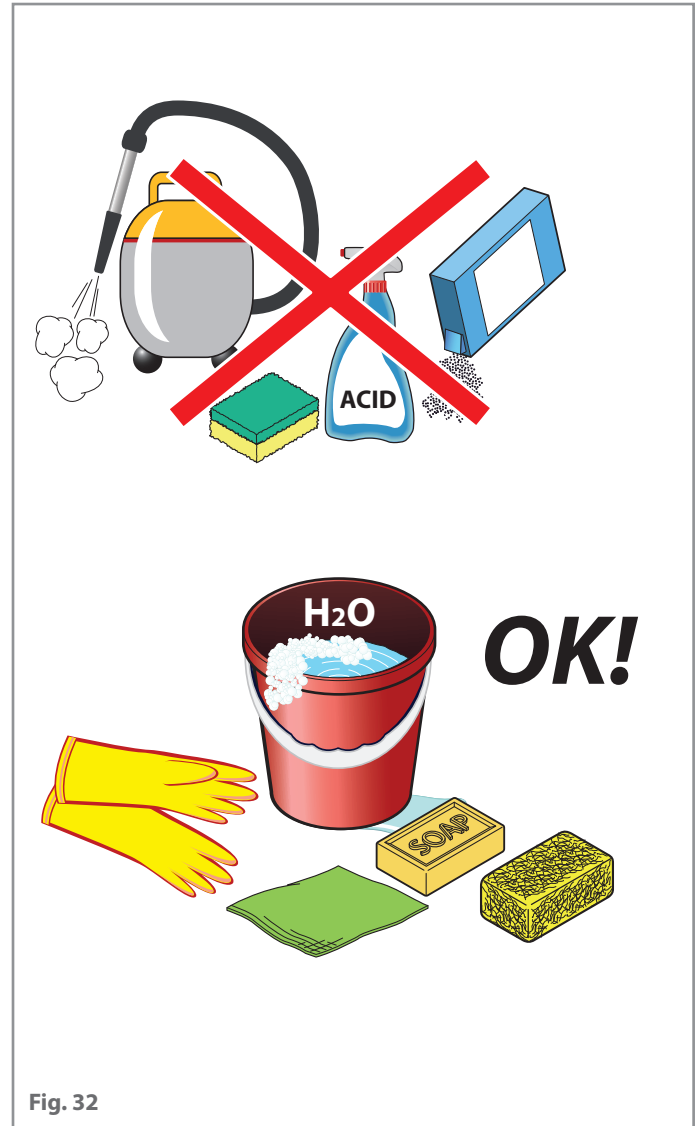

Fig. 32

Scheduling the cleaning

COMPONENT	WHEN TO CLEAN ...	HOW TO CLEAN ...
Internal cell and external parts	as required, according to the frequency of use	see page 43
Condenser	every 30 days maximum	see page 43
Needle probe	after every cycle	see page 44

Cleaning the internal cell and external parts

► Fig. 33

Carefully clean the **internal part of the cell** ①, the **door closing surface** ②, the **seal** ③ and the **appliance exterior** ④ using a soft cloth slightly soaked in soapy water. After cleaning, rinse with a soft cloth slightly soaked in water and dry carefully.

Proper internal cleaning of the equipment prevents the formation of bad odours that could damage the final product.

! Do not clean with abrasive tools or cloths that could release fibres.

! The only detergent allowed is soapy water: the use of different products can cause damage to the surfaces of the appliance and compromise the quality and wholesomeness of the food that has been blast chilled.

! Pay particular attention to cleaning the display ⑤: clean it with a very soft cloth slightly moistened with neutral and delicate detergent, suitable for crystal. Follow the detergent manufacturer's directions for use.

Cleaning the condenser

► Fig. 34

For the correct and efficient operation of the equipment, the condenser ⑥ must be kept clean to allow the free circulation of air: this operation must be done every **30 days maximum**.

! The condenser has sharp edges. During the operations described below, always wear protective gloves, goggles and respiratory protection.

Clean the condenser with a soft brush or, preferably, with a vacuum cleaner to avoid dispersing the dust in the environment. If there are greasy deposits, remove them using a brush soaked in alcohol.

! Do not scrape the fins with sharp or abrasive bodies.

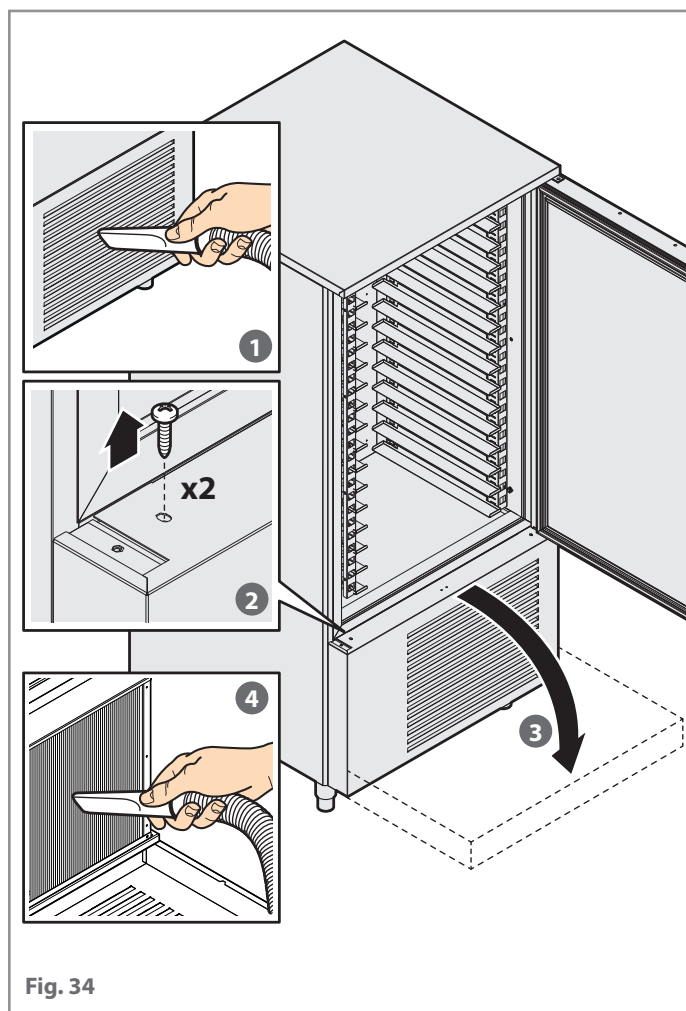
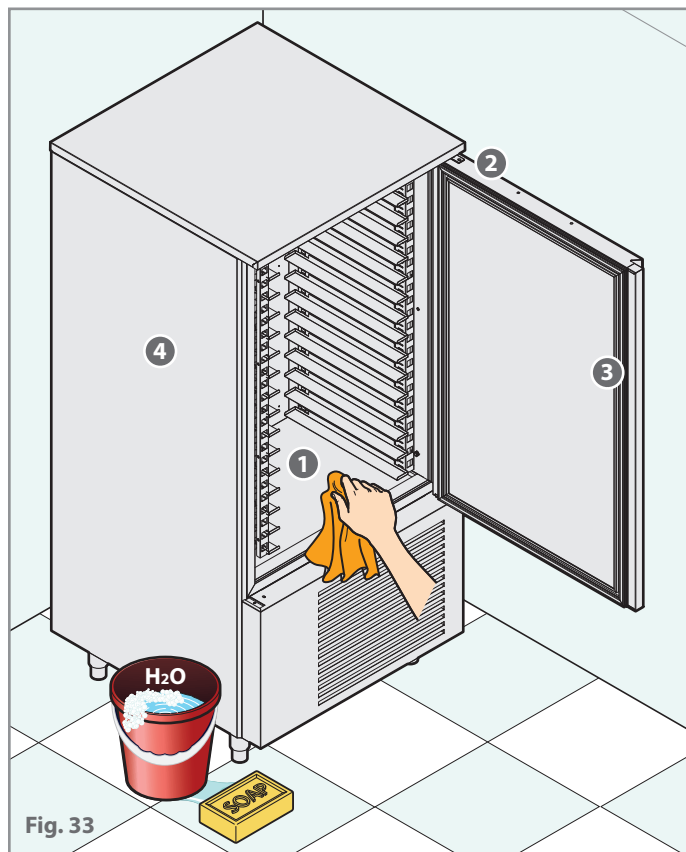



Cleaning the needle probe

► Fig. 35

Before starting a new cycle, in order to avoid any type of product "pollution", it is necessary to clean the needle probe. Remove any type of residue using a soft cloth soaked in neutral detergent. Rinse thoroughly and treat with a sanitizing product.

! Avoid pulling the probe cable: risk of damage.

! The probe has a particularly pointed tip. During cleaning, always wear protective gloves and pay close attention.

Downtime

During periods of inactivity, disconnect the power supply, and protect the external steel parts of the equipment by dusting them with a soft cloth just soaked with Vaseline oil.

Leave the door ajar in order to ensure proper air exchange.

On restarting, before use:

- clean the appliance thoroughly;
- reconnect the appliance to the power supply;
- check the appliance before using it again.

! **To make sure that the appliance is in perfect conditions of use and safety, we recommend that you have it serviced and checked at least once a year by an authorized service centre.**

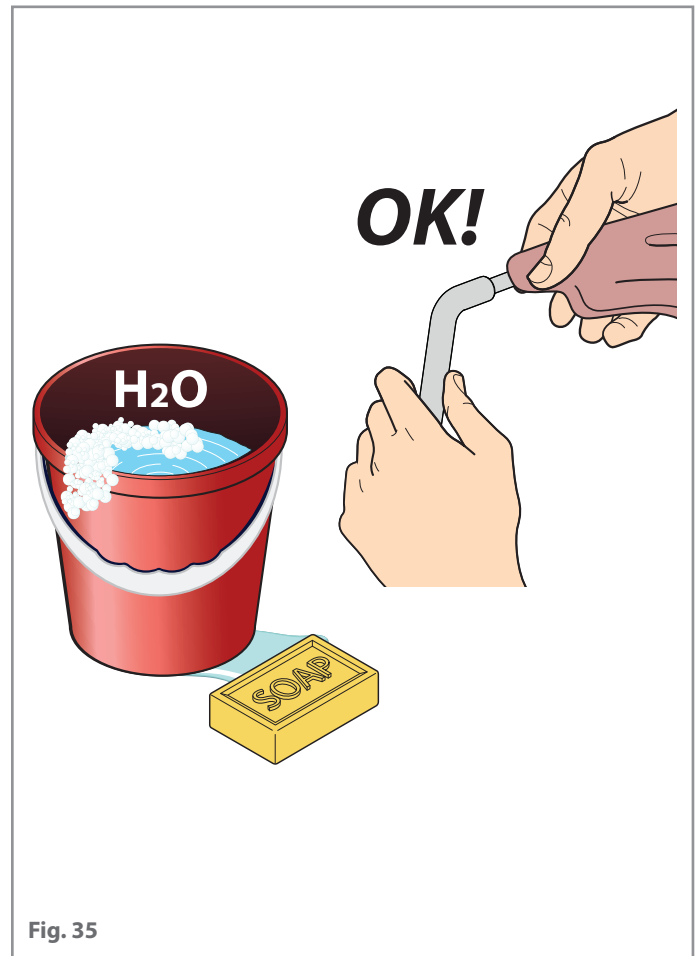

Fig. 35

Disposal



To avoid any unauthorized use and the risks associated with it before disposing of the equipment:

- **make sure that it is no longer possible to use it: for this purpose, the power supply cable must be cut or removed (with the appliance disconnected from the mains).**
- **ensure that no child can accidentally become trapped inside the blast chilling chamber while playing, to this end block the door opening (for example with adhesive tape or latches).**



The appliance is built with ferrous materials, electronic components and plastic. If it is necessary to dispose of it, separate the different components according to the material they are made of, in order to simplify the differentiated disposal or any reuse of the parts. Entrust the scrapping to appropriate disposal companies or, in the cases provided by law, return it to the dealer.

For scrapping, always refer to the laws in force in the country of use.



Pay attention that the equipment contains refrigerant gas whose control and recovery must be treated according to the provisions of the regulations in force in the country of disposal.

The equipment must be disposed of separately from municipal waste.



Pursuant to art. 13 of Legislative Decree No. 49 of 2014 "Implementation of the WEEE Directive 2012/19/EU on waste electrical and electronic equipment", the crossed-out wheeled bin mark means that the product was placed on the market after 13 August 2005 and that at the end of its useful life it must not be treated as other waste but must be disposed of separately. All the appliances are made of recyclable metal materials (stainless steel, iron, aluminium, galvanized sheet metal, copper, etc.)

in a percentage greater than 90% by weight.

It is necessary to pay attention to the management of this product at the end of its life by reducing any negative impacts on the environment and improving the efficiency of the use of resources, applying the principles of "polluter pays", prevention, preparation for reuse, recycling and recovery. Please note that the illegal or incorrect disposal of the product entails the application of the penalties provided for by current legislation.

Information on disposal in Italy

In Italy WEEE equipment must be delivered to:

- Collection Centres (also called ecological islands or ecological platforms)
- the dealer where you buy new equipment, who is required to accept it free of charge ("one on one" collection).

Information on disposal in European Union countries

The EU WEEE equipment directive has been adopted differently by each country, therefore if you want to dispose of this equipment we suggest you contact the local authorities or the dealer to ask for the correct method of disposal.



Your machine is reliable and robust but sometimes small problems can arise which, thanks to our Service Centres, will be promptly resolved.

In case of problems, carry out the following procedure:

- 1 Check for **error messages on the display**. Try to solve them by consulting the "SOLUTION", column, if it suggests you contact an Authorized Service Centre, do it.
- 2 The problem cannot be solved by the user, it is necessary to contact an Authorized Service Centre.

Fig. 36 Before doing so, record the **machine data**, the **date and the number of the equipment purchase invoice**, the **codes of any alarms** shown on the display:

serial number

invoice date.....

invoice number

alarm code.....

 If there is a need to send the equipment or parts to a Service Centre or to the Manufacturer (**after asking for prior authorization from the same**), the **ORIGINAL** packaging must be used. If it was not kept, use your own packaging, taking care that the equipment does not suffer further damage during transport; we recommend writing "FRAGILE-DO NOT TURN UPSIDE DOWN" on the outside of the packaging.

 **Do not attempt to repair the equipment yourself, this could cause serious damage to people, animals and property and voids the Warranty.** Request the intervention of an Authorized Service Centre and ask for ORIGINAL spare parts. Failure to comply with this prescription will void the Warranty.

Manufacturer's details

GEMM srl
Via del Lavoro, 37 - Loc. Cimavilla - 31013 CODOGNE' (TV) - ITALY
T. +39 0438 778504 – F. +39 0438 470249
e-mail: info@gemm-srl.com - www.gemm-srl.com

Warranty

The warranty on the components of the equipment, starting from the date shown on the delivery note, is as per the sales contract. The Warranty does not cover any damage to the equipment caused by:

- transport and/or handling;
- operator errors;
- lack of maintenance provided for in this manual;
- breakdowns and/or failures not attributable to the equipment malfunction;
- maintenance operations carried out by unqualified personnel;
- misuse.

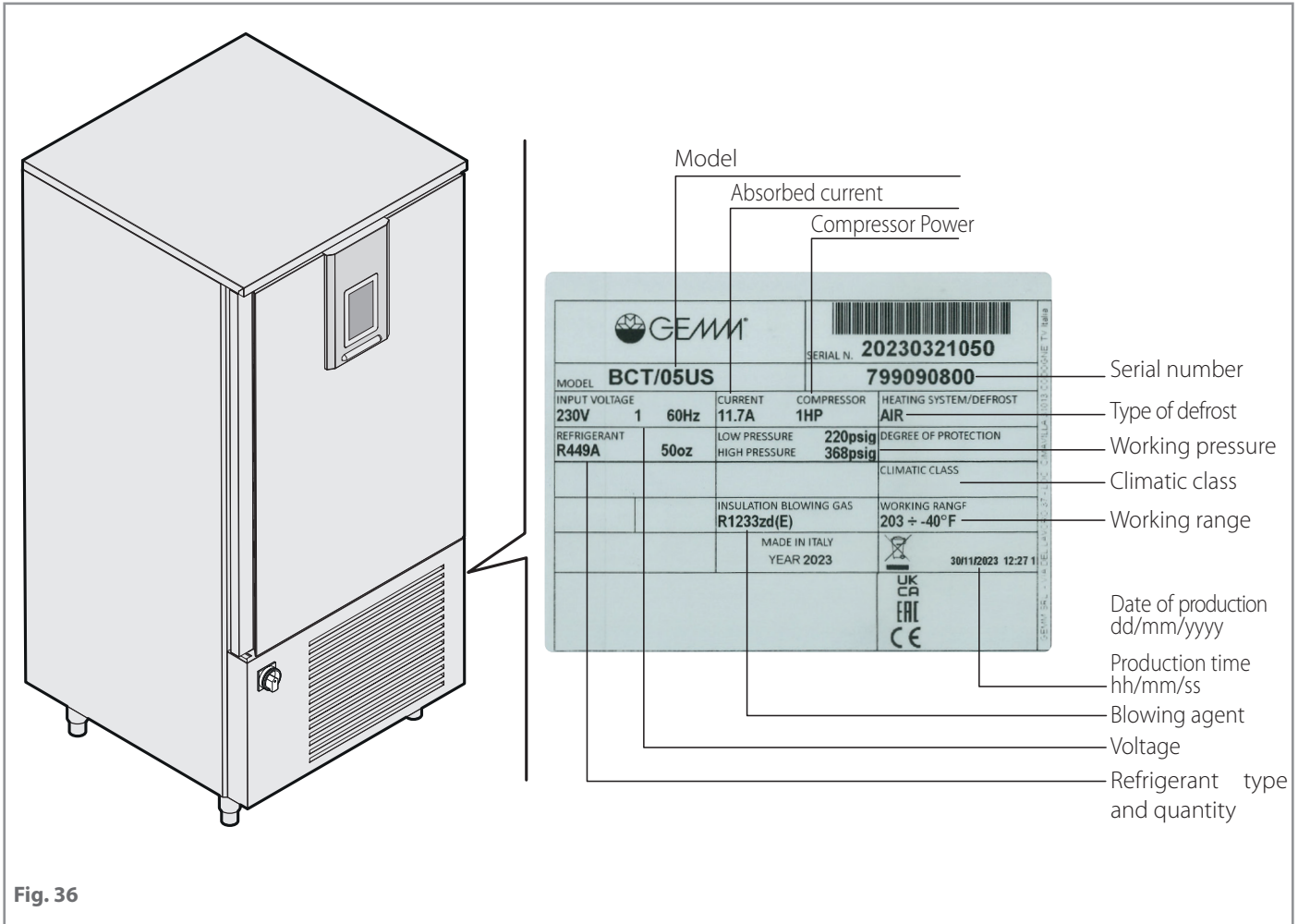

Fig. 36

ALARM	CAUSE	SOLUTION
RTC	Clock error: - the device will not store the date and time when an HACCP alarm occurs	Set the actual day and time again.
CELL PROBE	Cell probe error: - if the error occurs during the " stand-by ", you will not be able to select or start any operating cycle - if the error occurs during blast chilling or deep freezing , the cycle continues and the compressor runs continuously - if the error occurs during storage , the compressor's activity will depend on parameters C4 and C5 or C9 - if the error occurs during leavening, slow cooking or a thawing cycle , the cycle is interrupted	Contact an Authorized Service Centre
EVAPORATOR PROBE	Evaporator probe error	
CONDENSER PROBE	Condenser probe error	
NEEDLE 1/2/3 SENSOR	Needle probe error, the equipment will use any other available probes - if the error occurs during the " stand-by ", the operating cycles with the needle probe will start as timed - if the error occurs during temperature blast chilling, blast chilling will last according to the time set with parameter r1 - if the error occurs during temperature freezing, freezing will last according to the time set with parameter r1 - if the error occurs during the heating of the needle probe , heating will be interrupted	
THERMAL	Thermal protection alarm: the current cycle is always interrupted	
HIGH/LOW PRESSURE	High/low pressure alarm: if the cycle in progress uses the compressor, the cycle is interrupted.	
HIGH/LOW PRESSURE	Maximum or minimum temperature alarm (HACCP): - the device will store the alarm	
DOOR OPEN	The door is open	Close the door
CYCLE DURATION	Positive or negative blast chilling has not been completed within the maximum factory-set time (HACCP error): - the device will store the alarm	The blast chiller has probably been excessively or incorrectly loaded, try to perform a new cycle with smaller quantities. If the problem persists, contact an Authorized Service Centre
BASIC COMMUNICATION	User-control module interface communication error: - any cycle in progress will be terminated and it will not be possible to start one.	Contact an Authorized Service Centre
BASIC COMPATIBILITY	User-control module interface compatibility error: - any cycle in progress will be terminated and it will not be possible to start one.	
NEEDLE	Needle probe alarm (all enabled needle probes are in alarm): - any timed cycle will be interrupted	

ALARM	CAUSE	SOLUTION
POWER FAILURE	Power supply interruption alarm: - the device will store the alarm - the cycle in progress will restart when the power is reset - The alarm output will be activated	Check that the power supply has not been cut off (e.g. black-out), that the plug is correctly inserted and that the power cable is not damaged. If the problem persists, contact an Authorized Service Centre
SANITIZATION NEEDLE INSERTION	Sanitization alarm: - The sanitization cycle will be interrupted	Check the needle probe is inserted correctly. If the problem persists, contact an Authorized Service Centre
SANITIZATION DURATION	Sanitization not completed within the expected maximum duration (HACCP alarm): - the device will store the alarm - the current cycle will be interrupted - the alarm output will be activated.	
OVERHEATED COND.	Overheated condenser alarm. - The condenser fan will be turned on - the alarm output will be activated.	
BLOCKED COMP.	Blocked compressor alarm: - if the error occurs during the "stand-by" status, you will not be able to select or start any operating cycle - if the error occurs during an operating cycle, the cycle will be interrupted - the alarm output will be activated.	
NEEDLE INSERTION	Needle not inserted alarm: - The temperature cycle in progress is changed into a timed cycle	Check the needle probe is inserted correctly. If the problem persists, contact an Authorized Service Centre
EXPANSION COMMUNICATION	User-expansion module interface communication error: - any leavening or slow-cooking cycle in progress will be terminated and it will not be possible to start one.	
EXPANSION COMPATIBILITY	User-expansion module interface communication error - any cycle in progress will be terminated and it will not be possible to start one.	

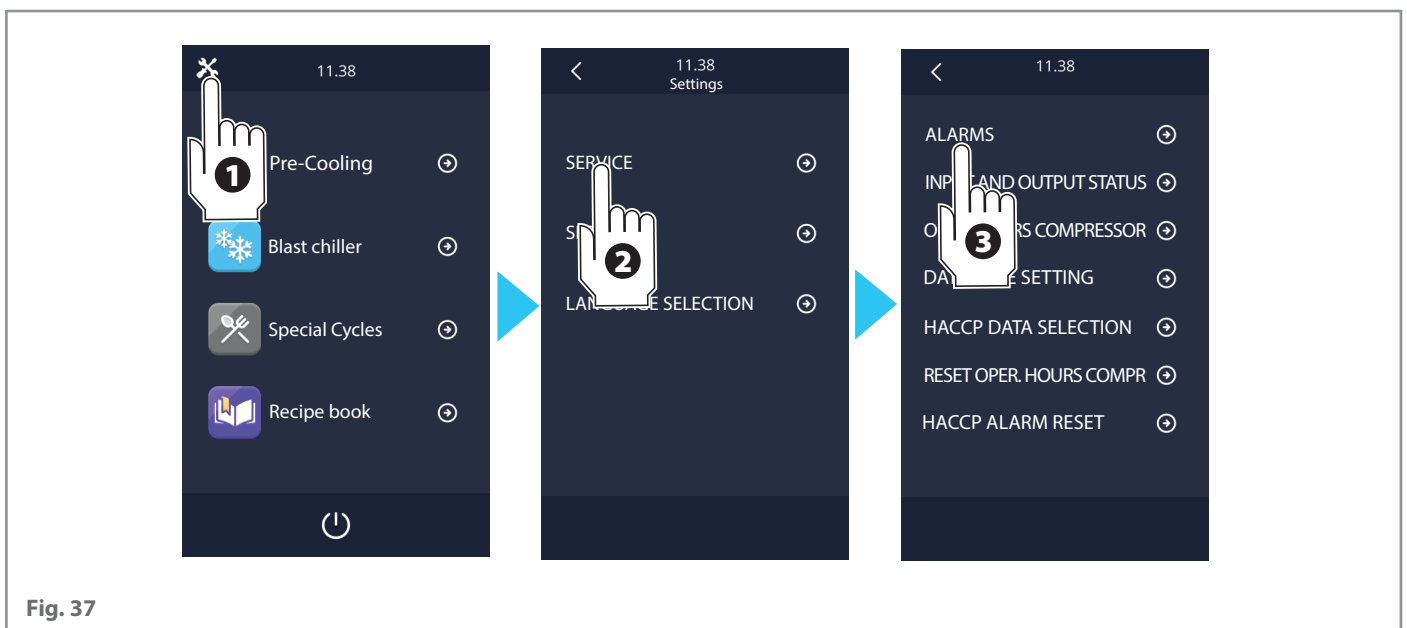

Fig. 37



GEMM srl

Via del Lavoro, 37 - Loc. Cimavilla - 31013 CODOGNE' (TV) - ITALY

T. +39 0438 778504 - F. +39 0438 470249

e-mail: info@gemm-srl.com - www.gemm-srl.com

Iscr.Reg.Impr. TV - CF e P. IVA 03441880261 - REA TV 272556

Registro Prod. AEE - TV n IT0802000001108

UNI EN ISO 9001:2008



CERT. N. 9105.GEMM