

# Krampouz®

## WECCBEAT



Get professional-grade waffles with Krampouz. This swivel waffle maker ensures even batter distribution across the cast-iron plates, delivering perfectly crisp waffles with every batch. Ideal for cafés, bakeries, and high-demand kitchens looking to add delicious, authentic waffles to their menu.

### FEATURES

- Swivel design allows smooth plate rotation for even batter distribution and consistent cooking results.
- Dual cooking plates let you produce four Brussels-style waffles at once, boosting efficiency during peak hours.
- Adjustable temperature control offers precise heat settings to suit different batter types and desired textures.
- Integrated drip tray helps keep the workstation clean by catching overflow and reducing mess.
- Non-stick cast-iron plates ensure effortless waffle release while minimizing the need for excess oil or butter.



PARTS AND  
LABOR



### TYPE OF WAFFLE



4 x 6 Brussels type

Dimensions of the waffles:

7.2" x 4.5" x 1.1"

(18.2 cm x 11.3 cm x 2.8 cm)

### SPECIFICATIONS

Power: 240 V – 2600 W

Plate: Cast iron

Batch: 4 waffles

Dimensions:

Length: 17.1" (44 cm)

Width: 19.4" (49 cm)

Height: 16.1" (41 cm)

Connection: 

(240 V)

Net weight: 77 lb (35 kg)



Intertek



Intertek

eurolib

1-888-956-6866  
customerservice@eurolib.com

eurolib.com



2026.04

### FRONTAL VIEW

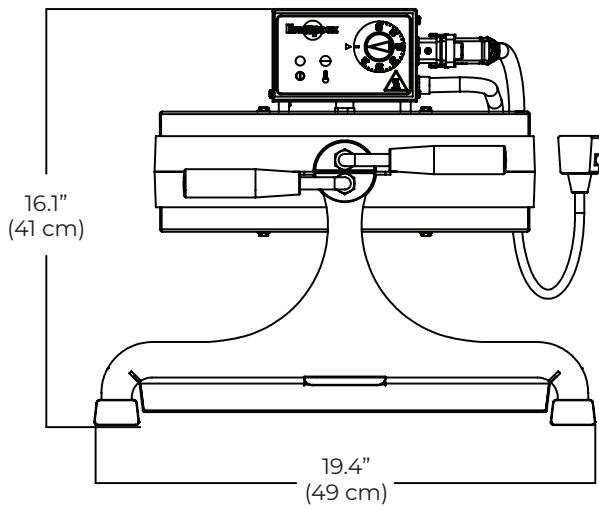

### TOP VIEW

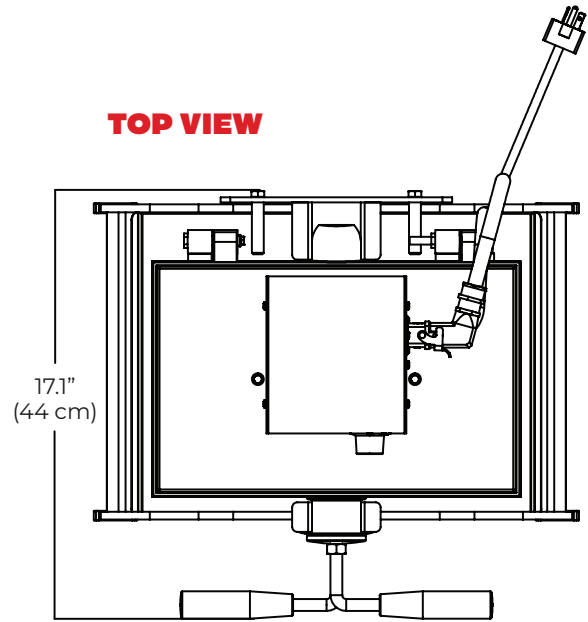

### LEFT VIEW

