

eurodib

M10ETL



Easily prepare delicious recipes with our smallest planetary mixer. This compact mixer delivers high-performance mixing capabilities, effortlessly blending ingredients without sacrificing valuable kitchen space.

FEATURES

- This mixer is an essential appliance for every commercial kitchen designed to handle all kinds of recipes with ease.
- Its durable stainless steel construction guarantees long-term reliability and consistent performance.
- The intuitive controls make operation simple and user-friendly.
- It offers exceptional value while ensuring quality assurance for professional results.
- The compact design is ideal for small kitchens, maximizing functionality without taking up much space.



PARTS AND
LABOR



SPECIFICATIONS

Power: 110 V, 600 W, 6 A, 5-15P

Capacity: 10.5 qt. (10 L)

Bowl depth: 12.5" (32 cm)

Bowl diameter: 10.5" (27 cm)

Mixing speeds: 67/189/362 rpm

Max. kneading capacity:
4.4 lbs/h (2 kg/h)

Dimensions:

Length: 19.4" (49 cm)

Width: 14.9" (37 cm)

Height: 26" (66 cm)

Connection: 
(110 V)

Net weight: 143 lb (65 kg)

Included accessories

- Spiral hook
- Whip
- Beater



FRONTAL VIEW

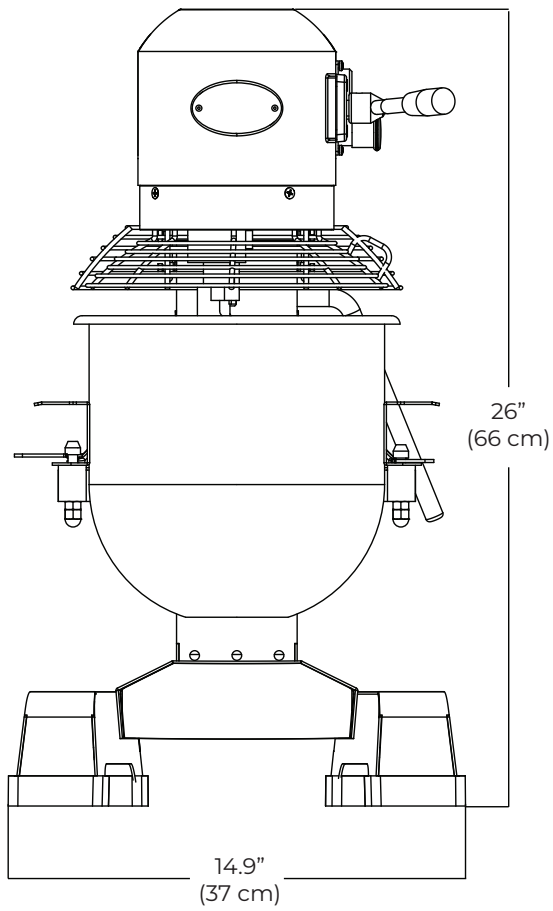

TOP VIEW

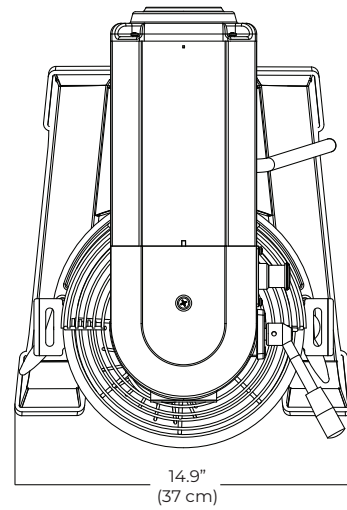

LEFT VIEW

